

AD2 **SCHWINN®**



Manual en Español Latino Americano:
<http://www.schwinnfitness.com>

ASSEMBLY MANUAL / OWNER'S MANUAL

TABLE OF CONTENTS

Important Safety Instructions - Assembly	3	Important Safety Instructions - Owner's	15
Safety Warning Labels / Serial Number	4	Features	16
Specifications	5	Console Features	17
Before Assembly	5	Operations	19
Parts	6	Adjustments	19
Hardware	7	Workout Mode	20
Tools	7	Pausing or Stopping	20
Assembly	8	Service Mode	21
Leveling the Bike	14	Maintenance	22
Moving the Bike	14	Replacing the Batteries	24
		Troubleshooting	25

To validate warranty support, keep the original proof of purchase and record the following information:

Serial Number _____

Date of Purchase _____

To register your product warranty , go to: www.SchwinnFitness.com/register

Or call 1 (800) 605-3369.

If you have questions or problems with your product, please call 1 (800) NAUTILUS (628-8458).

Nautilus, Inc., (800) NAUTILUS / (800) 628-8458, www.NautilusInc.com - Customer Service: North America (800) 605-3369, csnls@nautilus.com | outside U.S. +01-360-859-5180, technics-APLA@nautilus.com | Printed in China | © 2011 Nautilus, Inc., All rights reserved. ™ and ® indicate a trademark or registered trademark. Nautilus, Inc. (www.NautilusInc.com) trademarks include NAUTILUS®, BOWFLEX®, SCHWINN®, UNIVERSAL® and AIRDYNE® and respective logos. Other trademarks are the property of their respective owners.

IMPORTANT SAFETY INSTRUCTIONS

— ASSEMBLY



This icon means a potentially hazardous situation which, if not avoided, could result in death or serious injury.

Obey the following warnings:



Read and understand all warnings on this machine.

Carefully read and understand the Assembly instructions.

- Keep bystanders and children away from the product you are assembling at all times.
- Do not install the batteries into the machine until the time specified in the assembly manual.
- Do not assemble this machine outdoors or in a wet or moist location.
- Make sure assembly is done in an appropriate work space away from foot traffic and exposure to bystanders.
- Some components of the machine can be heavy or awkward. Use a second person when doing the assembly steps involving these parts. Do not do steps that involve heavy lifting or awkward movements on your own.
- Set up this machine on a solid, level, horizontal surface.
- Do not try to change the design or functionality of this machine. This could compromise the safety of this machine and will void the warranty.
- If replacement parts are necessary use only genuine replacement parts and hardware supplied by Nautilus. Failure to use genuine replacement parts can cause a risk to users, keep the machine from operating correctly and void the warranty.
- Do not use until the machine has been fully assembled and inspected for correct performance in accordance with the Manual.
- Read and understand the complete Manual supplied with this machine before first use. Keep the Manual for future reference.
- Do all assembly steps in the sequence given. Incorrect assembly can lead to injury or incorrect function.
- This product contains magnets. Magnetic fields can interfere with the normal use of certain medical devices at a close range. Users may come into proximity of the magnets in the assembly, maintenance, and/or use of the product. Given the obvious importance of these devices, such as a pacemaker, it is important that you consult with your medical provider in connection with the use of this equipment. Please consult the “Safety Warning Labels and Serial Number” section to determine the location of the magnets on this product.

SAFETY WARNING LABELS AND SERIAL NUMBER

 WARNING
<ul style="list-style-type: none">• Keep children away.• Prior to use, read and understand the Owners Manual.• Injury or death is possible if Caution is not used while using this machine.• The maximum user weight for this machine is 250lbs. (113kg).• Replace any "Caution" "Warning" or "Danger" label that is illegible, damaged, or removed.• This machine is for home use only.
 AVERTISSEMENT
<ul style="list-style-type: none">• Gardez les enfants et les animaux de compagnie éloignés de cette machine en tout temps.• Lisez et familiarisez-vous avec le Manuel du propriétaire et avec tous les avertissements avant d'utiliser cette machine.• Soyez prudent lorsque vous utilisez cet équipement pour ne pas vous infliger de graves blessures.• Cette machine supporte un poids maximal de 250lbs. (113kg).• Remplacez toute étiquette d'avertissement endommagée, illisible ou manquante.• Cette machine est à usage domestique uniquement.

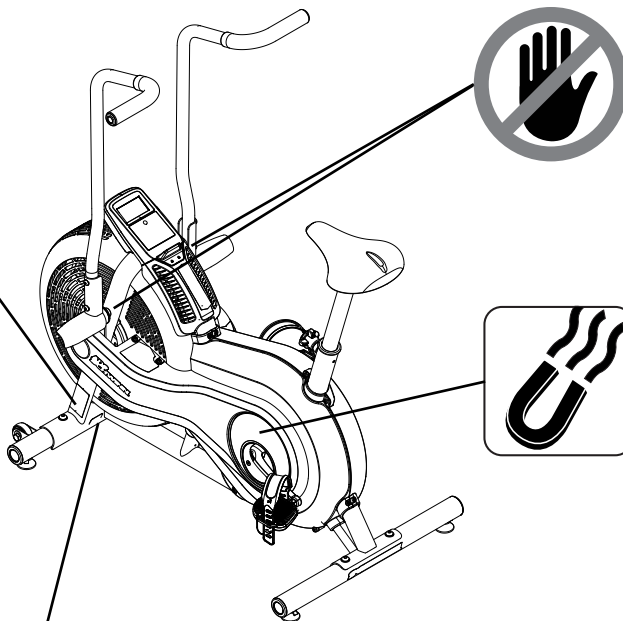

Serial number

SPECIFICATIONS

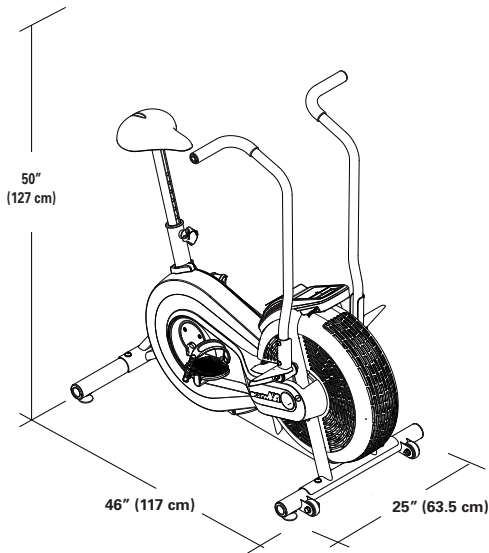

Maximum User Weight: 250 lbs. (113 kg)

Power Requirements: 2 AA batteries (LR6)
Operational Voltage: 1.0 - 3.3VDC



This product, its packaging, and components contain chemicals known to the State of California to cause cancer, birth defects, or reproductive harm. This Notice is provided in accordance with California's Proposition 65. If you would like additional information, please refer to our web site at www.nautilus.com/prop65.

Before Assembly

Select the area where you are going to set up and operate your machine. For safe operation, the location must be on a hard, level surface. Allow a workout area of a minimum 82" x 61" (2.1m x 1.5m).

Basic Assembly Tips

Follow these basic points when you assemble your machine:

1. Read and understand the "Important Safety Instructions" before assembly.
2. Collect all the pieces necessary for each assembly step.
3. Using the recommended wrenches, turn the bolts and nuts to the right (clockwise) to tighten, and the left (counterclockwise) to loosen, unless instructed otherwise.
4. When attaching 2 pieces, lightly lift and look through the bolt holes to help insert the bolt through the holes.
5. The assembly requires 2 people.

PARTS

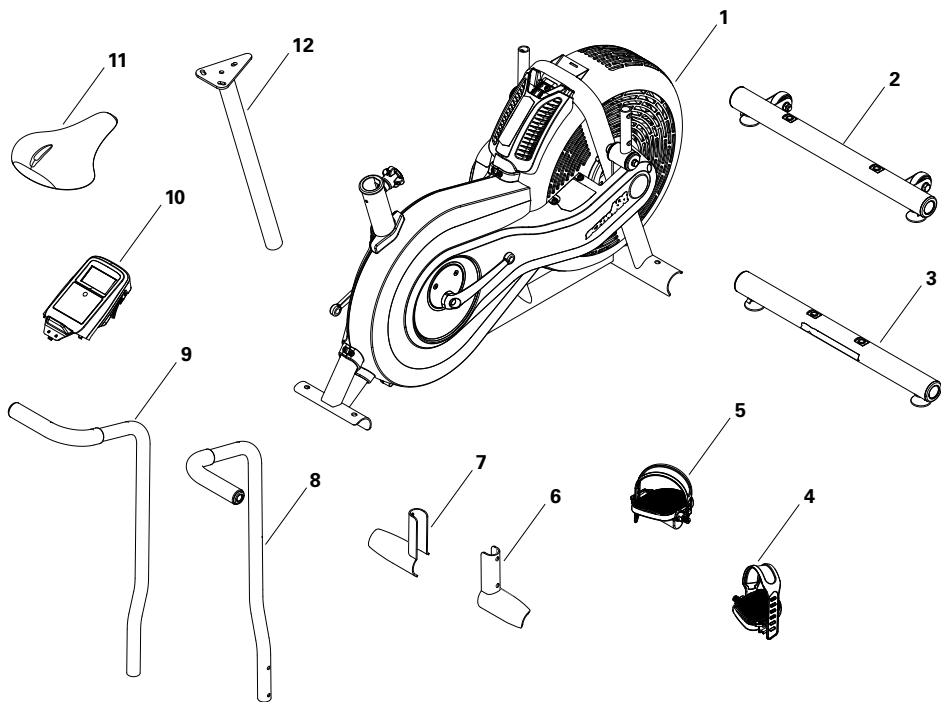

Item	Qty	Description	Item	Qty	Description
1	1	Main Frame	7	1	Foot Peg, Left
2	1	Front Stabilizer	8	1	Handlebar, Right
3	1	Rear Stabilizer	9	1	Handlebar, Left
4	1	Pedal, Right	10	1	Console
5	1	Pedal, Left	11	1	Seat
6	1	Foot Peg, Right	12	1	Seat Post

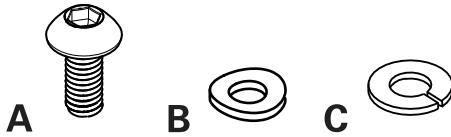

Item	Qty	Description
A	8	Button Head Hex Screw M8 x 20
B	8	Curved Washer M8
C	8	Lock Washer M8

Tools

Included



6 mm



Not Included



(recommended)



1. Attach Stabilizers to Frame Assembly

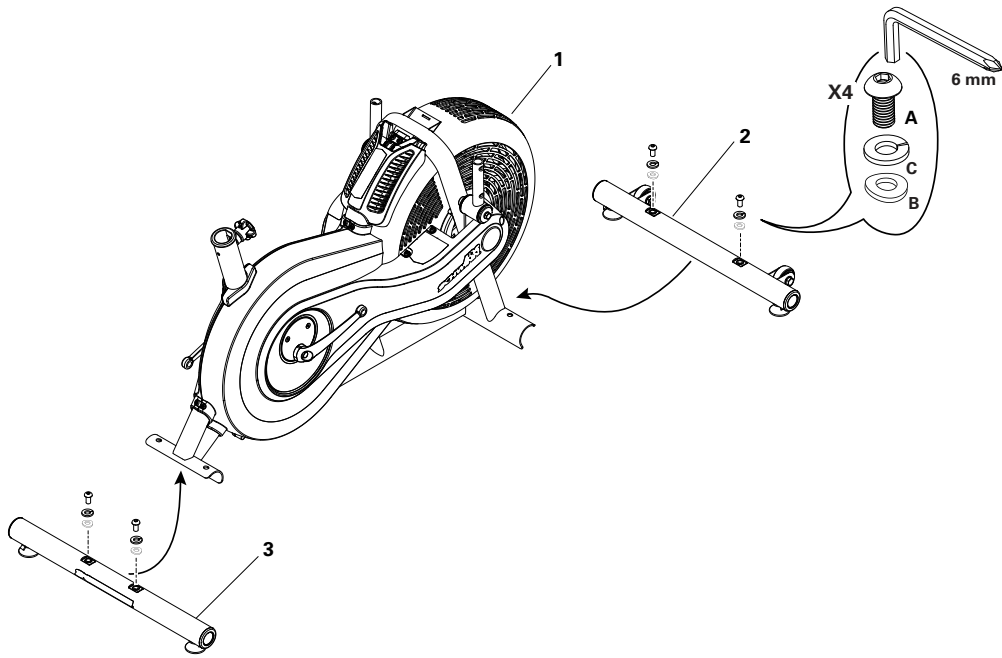

2. Attach Pedals

Note: The Left Pedal is reverse-threaded. Be sure to attach Pedals on the proper side of the Bike. Orientation is based from a seated position on the bike. The Left Pedal has an “L”, the Right Pedal an “R”.

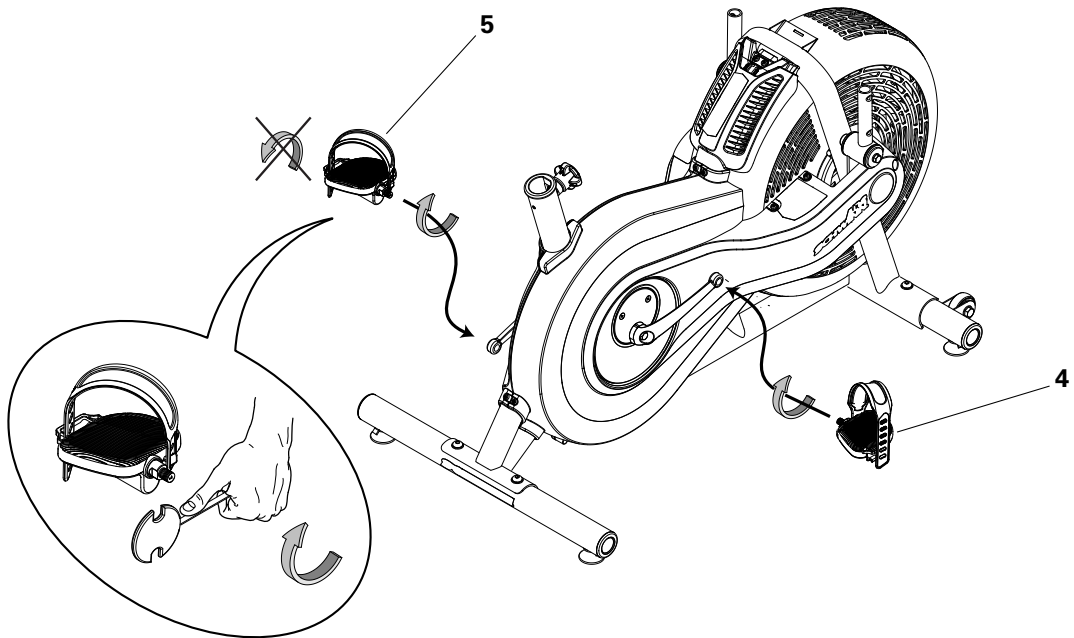

3. Attach Foot Pegs and Handlebar Arms

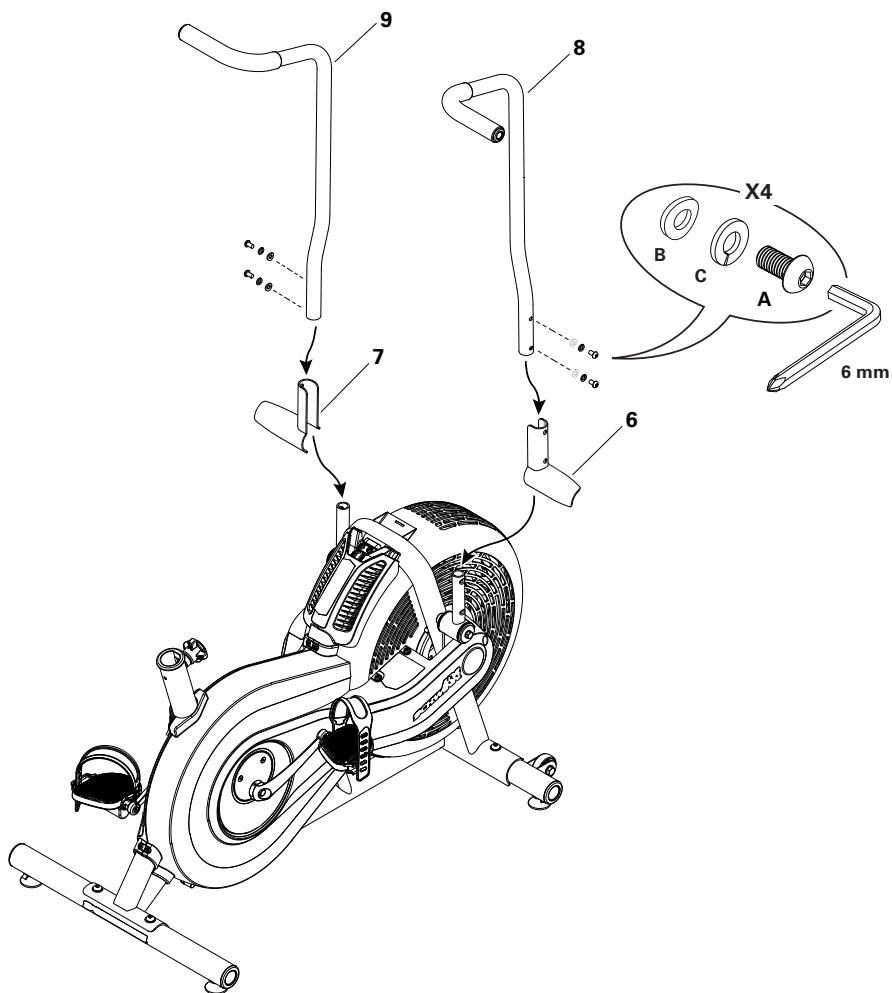

4. Install batteries in Console

Note: The console uses AA size batteries (LR6). Make sure that the batteries point in the direction of the +/– indicators in the battery bay.

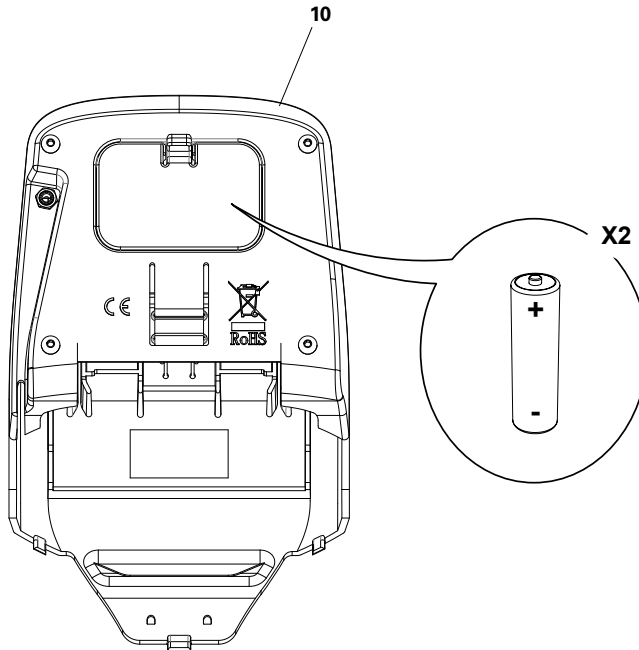

5. Attach the Console and Connect the Console Cable

NOTICE: Do not crimp Console Cable.

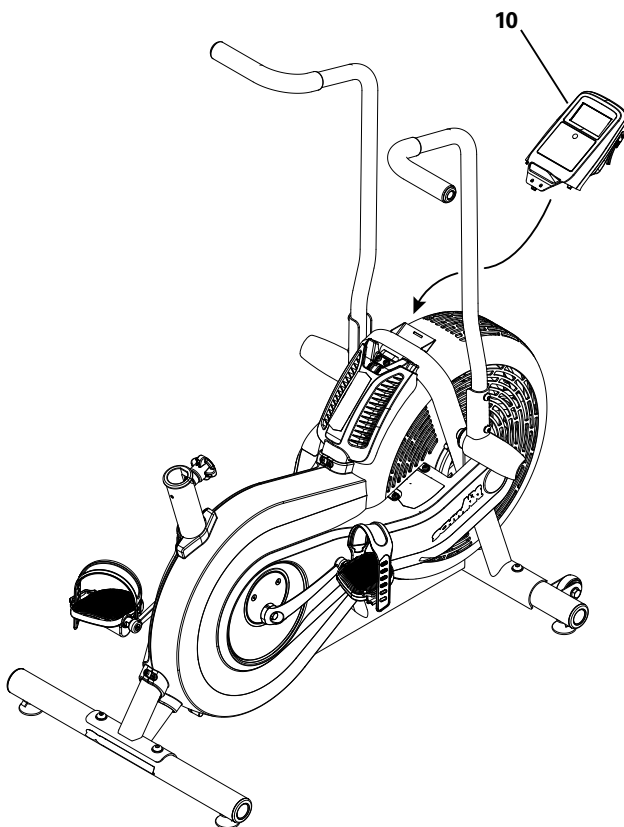
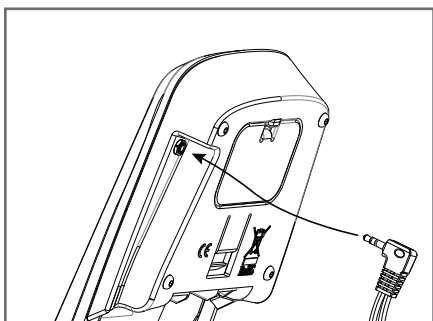
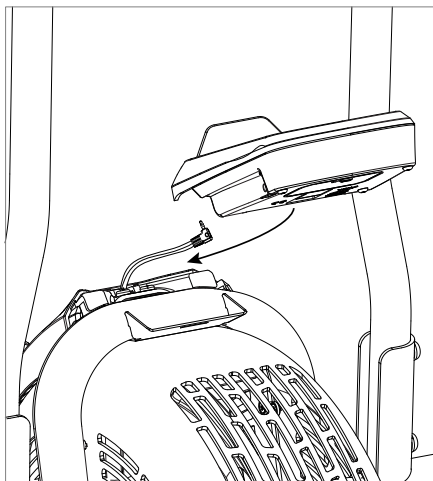

6. Attach Seat to Seat Post and Install on Frame Assembly

Note: Hardware is pre-installed on the seat and not on the hardware card.

NOTICE: Be sure the Seat is straight and tighten the hardware.

Make sure the adjustment knob (12a) engages the holes in the Seat Post.

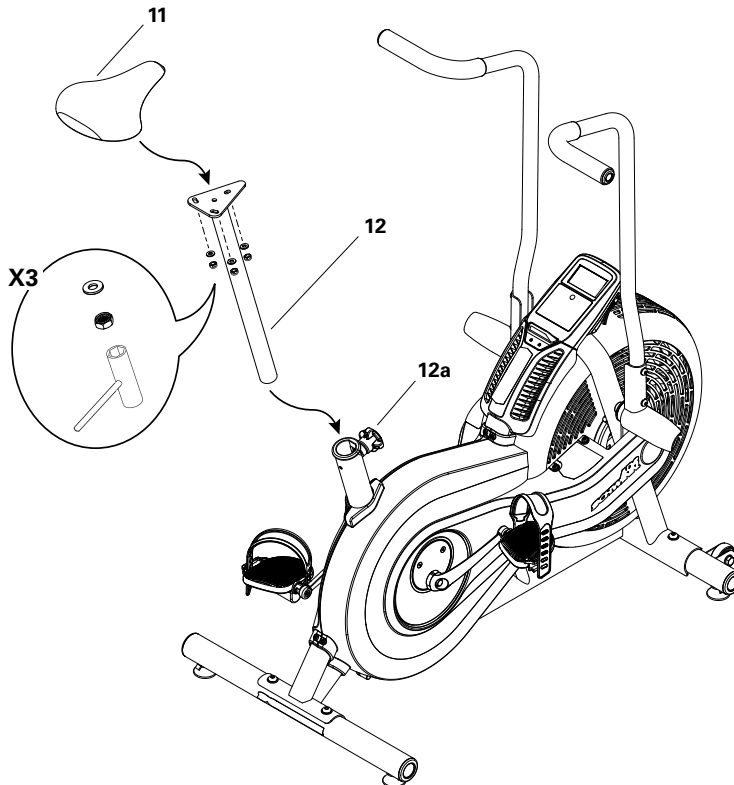

7. Final Inspection

Inspect your machine to ensure that all hardware is tight and components are properly assembled.

Be sure to record the serial number in the field provided at the front of this manual. Refer to the Safety Warning Labels and Serial Number section of this manual.

! Do not use or put the machine into service until the machine has been fully assembled and inspected for correct performance in accordance with the Owner's Manual.

BEFORE YOU START

Leveling Your Machine

If your workout area is uneven, you must level your machine. To adjust:

1. Loosen the upper locking nut.
2. Turn the leveler to adjust the height.
3. Tighten the upper locking nut to lock the leveler.

! Do not adjust the levelers to such a height that they detach or unscrew from the machine. Injury to you or damage to the machine can occur.

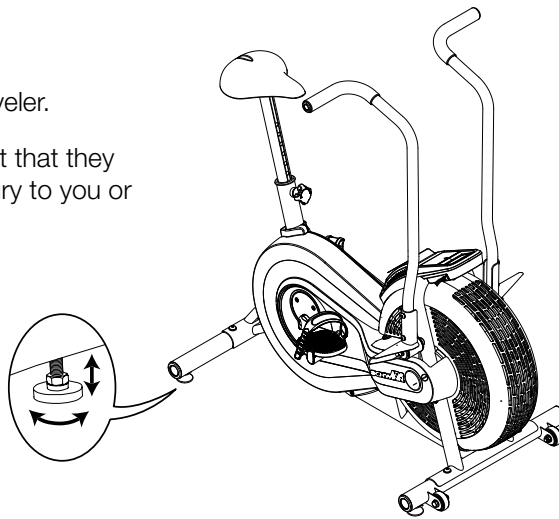

Moving Your Machine

To move the machine, carefully lift the rear end of the machine and slowly push the machine to the desired location. Be sure to keep the fan assembly clear of the floor.

NOTICE: Be careful when you move the machine. Abrupt motions can affect the computer operation.



IMPORTANT SAFETY INSTRUCTIONS

 This icon means a potentially hazardous situation which, if not avoided, could result in death or serious injury.

Before using this equipment, obey the following warnings:

-  Read and understand the complete Manual. Keep the Manual for future reference.
- Read and understand all warnings on this machine. If at any time the Warning stickers become loose, unreadable or dislodged, contact Nautilus® Customer Service for replacement stickers.
- Children must not be let on or near to this machine. Moving parts and other features of the machine can be dangerous to children.
 - Not intended for use by anyone under 14 years of age.
 - Consult a physician before you start an exercise program. Stop exercising if you feel pain or tightness in your chest, become short of breath, or feel faint. Contact your doctor before you use the machine again. Use the values calculated or measured by the machine's computer for reference purposes only.
 - Before each use, examine this machine for loose parts or signs of wear. Do not use if found in this condition. Monitor the Seat, Pedals, and Crank Arms closely. Contact Nautilus® Customer Service for repair information.
 - Maximum user weight limit: 250 lbs. (113 kg). Do not use if you are over this weight.
 - This machine is for home use only.
 - Do not wear loose clothing or jewelry. This machine contains moving parts. Do not put fingers or other objects into moving parts of the exercise equipment.
 - Set up and operate this machine on a solid, level, horizontal surface.
 - Make the Pedals stable before you step on them. Use caution when you step on and off the machine.
 - Disconnect all power before servicing this machine.
 - Do not operate this machine outdoors or in moist or wet locations. Keep the foot pedals clean and dry.
 - Keep at least 24" (0.6 m) on each side of the machine clear. This is the recommended safe distance for access and passage around and emergency dismounts from the machine. Keep third parties out of this space when machine is in use.
 - Do not over exert yourself during exercise. Operate the machine in the manner described in this manual.
 - Correctly adjust and safely engage all Positional Adjustment Devices. Make sure that the Adjustment Devices do not hit the user.
 - Exercise on this machine requires coordination and balance. Be sure to anticipate that changes in speed and resistance level can occur during workouts, and be attentive in order to avoid loss of balance and possible injury.

FEATURES

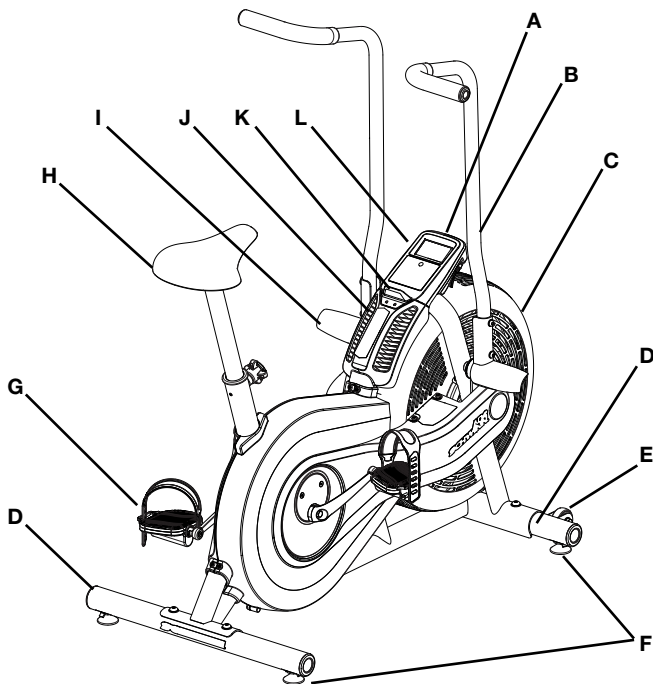

A	Console	G	Pedals
B	Handlebars	H	Adjustable Seat Assembly
C	Fan Assembly	I	Foot Rests
D	Stabilizers	J	Air Vents
E	Transport Wheels	K	Magazine Holder
F	Levelers	L	Battery Bay

Console Features

The Console provides information about your workout on the display screen. You can also use the button to get access to information about console settings.

Front

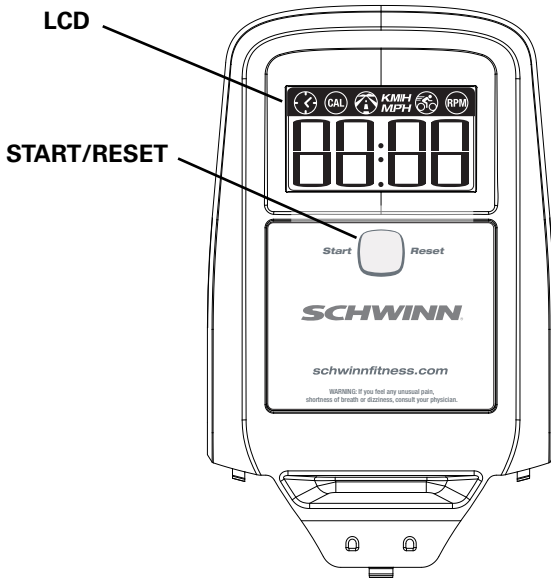

Back

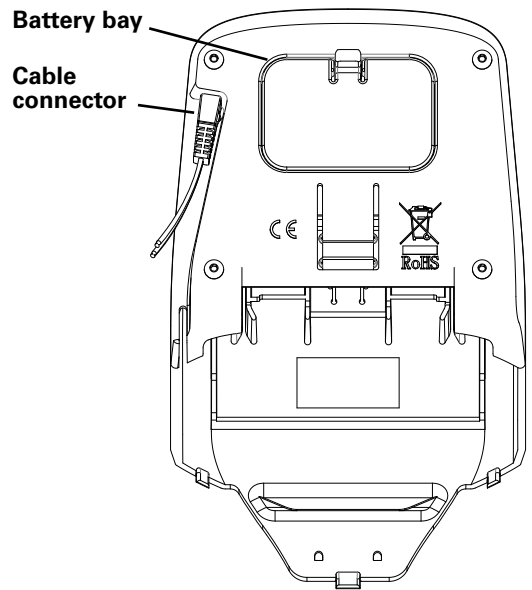

START/RESET

Push to start, or to stop an active workout and reset the Time to 0:00.

LCD Display Data

The console display shows each workout measurement in sequence for 5 seconds:

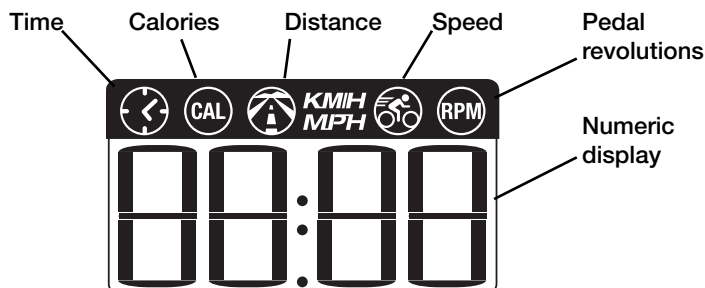

Time

The TIME display field shows the time count in the workout. The maximum display is 99:59. If the time count is more, the display starts again at 0:00.

CAL

The CAL display field shows the estimated calories that you have burned during the exercise. The maximum display is 9999. If the calorie count is more, the display flashes 9999.

Distance

The DISTANCE display field shows the distance count (miles or km) in the workout, to two decimal places—for example, 1.50. The maximum display is 99.99. If the distance is more, the display starts again at 0.00.

Note: To change the measurement units to English Imperial or metric, refer to the “Service Mode” section in this manual.

Speed

The SPEED display field shows the machine speed in kilometers per hour (km/h) or miles per hour (mph), to one decimal place—for example, 10.5 or 0.0. The maximum display is 99.9.

RPM

The RPM display field shows the machine revolutions per minute (RPM). The maximum display is 200.

What to Wear

Wear rubber-soled athletic shoes. You will need the appropriate clothes for exercise that allow you to move freely.

How Often Should You Exercise

⚠ Consult a physician before you start an exercise program. Stop exercising if you feel pain or tightness in your chest, become short of breath, or feel faint. Contact your doctor before you use the machine again. Use the values calculated or measured by the machine's computer for reference purposes only.

- 3 times a week for 30 minutes each day.
- Schedule workouts in advance.

Seat Adjustment

Correct seat placement encourages exercise efficiency and comfort, while reducing the risk of injury.

1. With a Pedal in the forward position, center the ball of your foot over the center of it. Your leg should be bent slightly at the knee.
2. If your leg is too straight or your foot cannot touch the Pedal, move the seat down on the upright bike. If your leg is bent too much, move the seat up on the upright bike.

⚠ Step off the bike before you adjust the seat.

Loosen and pull the adjustment knob on the seat tube. Adjust the seat to the desired height. Release the adjustment knob to engage the locking pin. Be sure that the pin is fully engaged and fully tighten the knob.

⚠ Do not lift the Seat Post above the MAX mark on the tube.

Foot Position / Pedal Strap Adjustment

Foot pedals with straps provide secure footing to the exercise bike.

1. Put the ball of each foot on the Pedals.
2. Fasten the strap over the shoe.
3. Repeat for the other foot.

Be sure toes and knees point directly forward to ensure maximum Pedal efficiency. Pedal straps can be left in position for subsequent workouts.

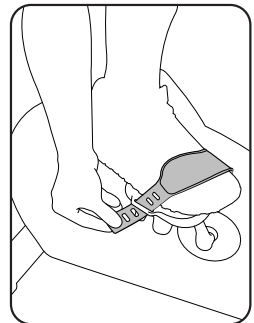
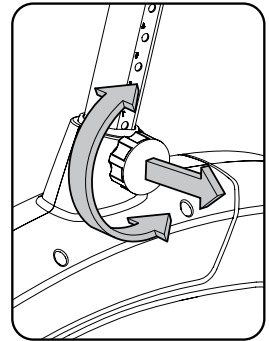

Workout Mode

The Console starts Workout Mode if the button is pushed, or if it receives a signal from the RPM sensor as a result of pedaling the machine. The Time starts to count up from 0:00.

Note: If the battery level is low, the Console display shows “Batt” for 10 seconds or until the button is pushed.

The Console calculates the workout data as you exercise. The Console display shows the current readings for: Time, Calories, Distance, Speed and RPM.

Changing the Resistance Level

The resistance automatically increases as you pedal the bike faster.

Pausing or Stopping the Workout

1. The Console pauses if the pedaling is less than 5 RPM for 3 seconds. During Pause state, the console display shows Time, Calories, Total Distance, Average Speed and Average RPM.

Start to pedal at 5 RPM or more to continue your workout.

After 5 minutes in Pause Mode, the workout stops and the Console goes into Sleep Mode.

2. Push the button to stop the workout. The Time count is reset to 0:00 and starts to count again. The time and distance data from the workout are added to the machine statistics (Total Time and Total Distance).

Auto Shut-Off (Sleep Mode)

If the Console does not receive any input in approximately 5 minutes, it will automatically shut off. The LCD display is off while in Sleep Mode.

Service Mode lets you set the units of measure to either English or Metric, see machine statistics and firmware version (for technician use only).

1. When the Console is in Workout Mode or Pause Mode, push and hold down the button for 5 seconds to go into Service Mode.

Note: Tap the button to move through the Service Mode Menu options. When the Console display shows “dOnE”, push and hold the button for 3 seconds to reset the workout data and go back to Workout Mode.

2. The Console display shows the Units prompt. Push and hold the button to start Units option. Push the button to change between “LbS” (English units) and “SI” (metric units).
3. Push and hold the button for 3 seconds to set the units. The Console display shows the Units prompt.
4. Push the button to go to the Stats prompt. Push and hold the button to start the machine Stats option. The Console display shows Total Distance. Push the button to change between Total Distance and Total Time.

Note: The Total Distance value is a whole number of miles/km (no decimal point).

5. Push and hold the button for 3 seconds to go back to the Stats prompt.
6. Push the button to go to the Firmware Version prompt. Push and hold the button to see the firmware version of the Console.
7. Push and hold the button for 3 seconds to go back to the Firmware Version prompt.
8. Push the button to go to the exit option. The Console display shows “dOnE”.

To go back to Workout Mode, push and hold the button for 3 seconds. The workout data is reset.

To go through the Service Mode Menu again, tap the button. The Console display will show the Units prompt.

In Service Mode if the Console does not receive any input in approximately 5 minutes, it goes into Sleep Mode.

MAINTENANCE

Read all maintenance instructions fully before you start any repair work. In some conditions, an assistant is necessary to do the necessary tasks.



Equipment must be regularly examined for damage and repairs. The owner is responsible to make sure that regular maintenance is done. Worn, damaged or loose components must be repaired or replaced immediately. Only manufacturer supplied components can be used to maintain and repair the equipment.

Daily:

Before each use, examine the exercise machine for loose, broken, damaged, or worn parts. Do not use if found in this condition. Repair or replace all parts at the first sign of wear or damage. After each workout, use a damp cloth to wipe your machine and Console free of sweat.

Note: Avoid excessive moisture on the Console.

Weekly:

Clean the machine to remove any dust, dirt, or grime from the surfaces. Check for smooth seat and handlebar operation. If needed, sparingly apply a thin coating of silicone lube to ease operation.

Note: Do not use petroleum based products.

Monthly or after 20 hours:

Check pedals, crank arms and handlebars, and tighten as necessary. Make sure all bolts and screws are tight. Tighten as necessary.

NOTICE: Do not clean with a petroleum based solvent or an automotive cleaner. Be sure to keep the Console free of moisture.

Maintenance Parts

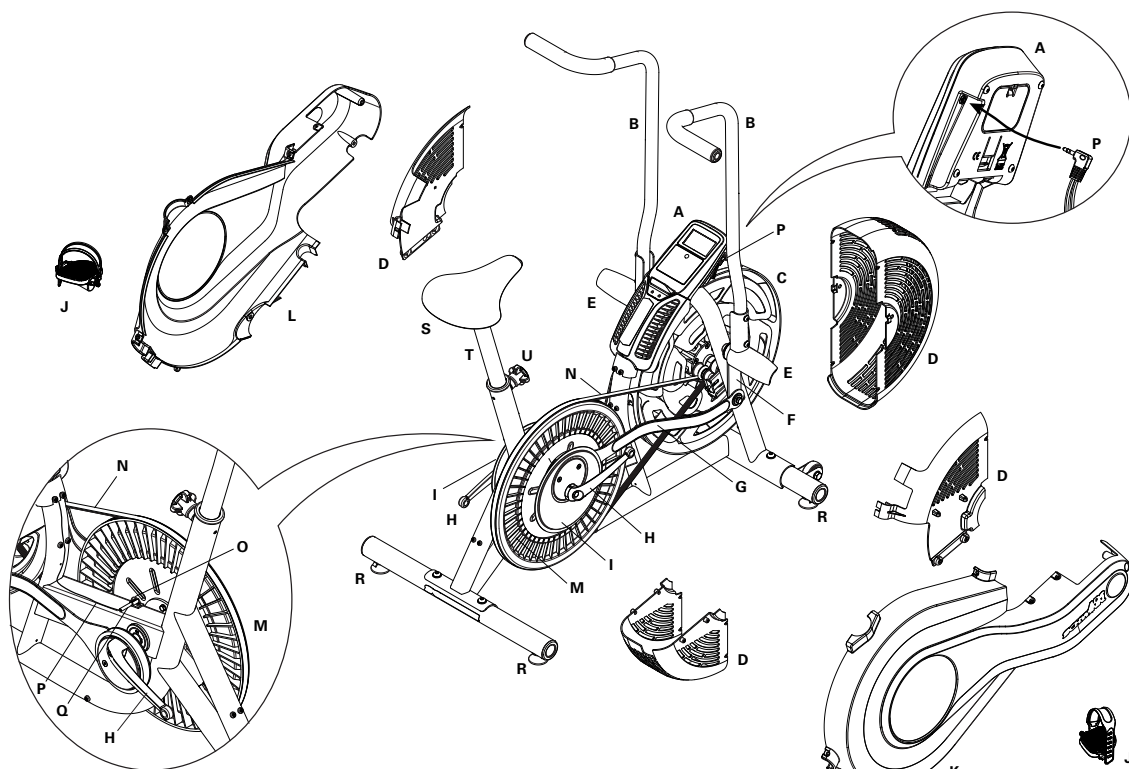

A	Console	H	Crank Arms	O	Speed Sensor Magnet
B	Handlebars	I	Crank Covers	P	Data Cable
C	Fan Assembly	J	Pedals	Q	RPM Sensor
D	Fan Assembly Covers	K	Shroud, Right	R	Levelers
E	Footpegs	L	Shroud, Left	S	Seat
F	Arm Pivots	M	Drive Pulley	T	Seat Post
G	Connector Arms	N	Drive Belt	U	Adjustment Knob

Replacing the Console Batteries

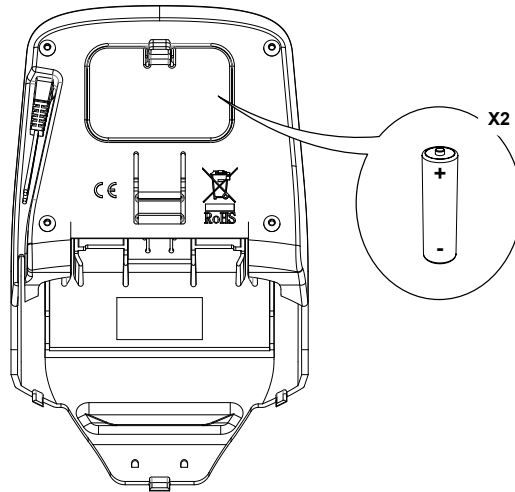

The Console display will show “Batt” during power up if the battery level is low. When replacing the batteries, make sure the batteries point in the +/– direction shown in the battery bay.

Note: The console uses AA size batteries (LR6).



Do not mix old and new batteries.

Do not mix alkaline, standard (carbon-zinc), or rechargeable (Ni-Cd, Ni-MH, etc) batteries.

Be sure to remove the batteries to prevent corrosion damage if you are not going to use the machine for an extended period of time.

Condition/Problem	Things to Check	Solution
Console will not power up/turn on/start	Batteries	Make sure batteries are installed correctly. If batteries are correctly installed, replace with a set of new batteries.
	Check data cable integrity	All wires in cable should be intact. If any are visibly crimped or cut, replace cable.
	Check data cable connections/orientation	Make sure cable is connected securely and oriented properly. Small latch on connector should line up and snap into place.
	Check console display for damage	Check for visual sign that console display is cracked or otherwise damaged. Replace Console if damaged.
		If the above steps do not resolve the problem, contact Customer Care for further assistance.
Speed displayed is not accurate	Display set to wrong unit of measure. (English/Metric)	Change display units.
Speed displayed is always "0"/stuck in Pause mode	Data cable	Make sure the data cable is connected to the back of the Console and the main frame assembly.
No speed/RPM reading	Check data cable integrity	All wires in cable should be intact. If any are cut or crimped, replace cable.
	Check data cable connections/orientation	Be sure cable is connected securely and oriented properly. Small latch on connector should line up and snap into place.
	Check magnet position (requires shroud removal)	Magnet should be in place on pulley.

	Check RPM Sensor (requires shroud removal)	RPM sensor should be aligned with magnet and connected to data cable. Realign sensor if necessary. Replace if there is any damage to the sensor or the connecting wire.
Console shuts off (enters sleep mode) while in use	Check data cable integrity	All wires in the cable should be intact. If any are cut or crimped, replace cable.
	Check data cable connections/orientation	Be sure cable is connected securely and oriented properly. Small latch on connector should line up and snap into place.
	Check magnet position (requires shroud removal)	Magnet should be in place on pulley.
	Check RPM Sensor	Contact Customer Care for further assistance.
Unit rocks/does not sit level	Check leveler adjustment	Leveling feet may be turned in or out to level bike.
	Check surface under unit	Adjustment may not be able to compensate for extremely uneven surfaces. Move bike to level area.
Pedals loose/unit difficult to pedal	Check pedal to crank connection	Pedal should be tightened securely to crank. Be sure connection is not cross-threaded.
	Check crank to axle connection	Crank should be tightened securely to axle.
Clicking sound when pedaling	Check pedal to crank connection	Remove pedals and reattach fully.
Seat post movement	Check locking pin	Be sure adjustment pin is locked into one of the seat post adjustment holes.
	Check adjustment knob	Be sure knob is securely tightened.





Nautilus®

Bowflex®

Schwinn® Fitness

Universal®