

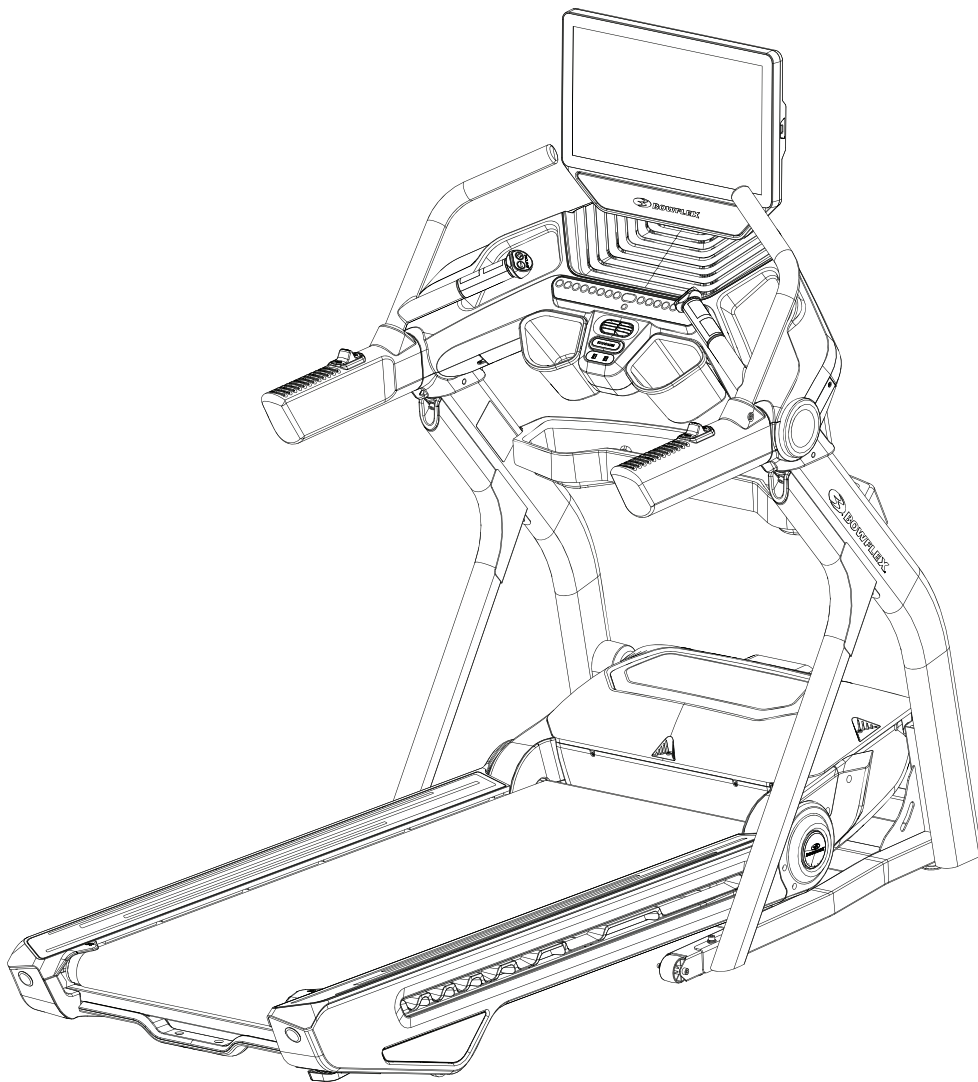

# Treadmill 22 / Treadmill 56

ASSEMBLY / OWNER'S MANUAL



# Welcome to the Bowflex™ Treadmill 22 / Treadmill 56 machine!

You're about to experience an incredible workout that can help you lose weight and reshape your entire body so you'll look and feel better than ever before. We thank you for trusting in the Bowflex brand.

Use this Manual as a guide to getting started on your Bowflex™ workouts and for tips to keep your machine well maintained.

Yours in Health,  
The Bowflex Family

## Table of Contents

Important Safety Instructions .....	3	Operations .....	47
Safety Warning Labels and Serial Number.....	5	Initial Console Set-Up .....	47
Grounding Instructions .....	6	Getting Started .....	47
Emergency Stop Procedure .....	7	Power Up Mode / Just For You tab .....	48
Specifications / Before Assembly .....	8	Pausing or Stopping .....	49
Parts .....	9	Power Off and Restart the Machine .....	49
Hardware / Tools .....	10	Maintenance .....	50
Assembly .....	10	Adjust the Belt Tension .....	51
Moving Your Machine .....	27	Aligning the Walking Belt .....	51
Unfolding the Machine.....	29	Lubricating the Walking Belt .....	52
Leveling Your Machine .....	30	Maintenance Parts.....	53
Features .....	31	Troubleshooting.....	55
Console .....	32	Body Weight Loss Guide .....	57
Bluetooth® Heart Rate Armband .....	37	Warranty .....	67
Bluetooth® Audio .....	38		
Fitness Basics .....	40		

To validate warranty support, keep the original proof of purchase and record the following information:

**Serial Number** \_\_\_\_\_

**Date of Purchase** \_\_\_\_\_

**If purchased in US/Canada:** To register your product warranty, go to: [www.bowflex.com/register](http://www.bowflex.com/register) or call 1 (800) 605-3369.

**If purchased outside US/Canada:** To register your product warranty, contact your local distributor.

For warranty and service of products purchased outside US/Canada, please contact your local distributor. Nautilus, Inc. will cover the frame and drive motor. Contact your local distributor for key details. To find your local international distributor, go to: [www.nautilusinternational.com](http://www.nautilusinternational.com).

Nautilus, Inc., 5415 Centerpoint Parkway, Groveport, OH 43125 USA, [www.NautilusInc.com](http://www.NautilusInc.com) - Customer Service: North America (800) 605-3369, [csnls@nautilus.com](mailto:csnls@nautilus.com) | Nautilus (Shanghai) Fitness Equipments Co, Ltd, Room 1701 & 1702, 1018 Changning Road, Changning District, Shanghai, China 200042, [www.nautilus.cn](http://www.nautilus.cn) - 86 21 6115 9668 | outside U.S. [www.nautilusinternational.com](http://www.nautilusinternational.com) | Printed in China | © 2020 Nautilus, Inc. | Bowflex, the B logo, JRNY, Nautilus, and Schwinn are trademarks owned or licensed by Nautilus, Inc., registered or otherwise protected by common law in the U.S. and other countries. Android™, Google Play™, and Nut Thins® are trademarks of their respective owners. Apple and the Apple logo are trademarks of Apple Inc., registered in the U.S. and other countries. App Store is a service mark of Apple Inc. The Bluetooth® word mark and logos are registered trademarks owned by Bluetooth SIG, Inc., and any use of such marks by Nautilus, Inc. is under license. Other trademarks are the property of their respective owners.

ORIGINAL MANUAL - ENGLISH VERSION ONLY

# IMPORTANT SAFETY INSTRUCTIONS

When using an electrical appliance, basic precautions should always be followed, including the following:

 This icon means a potentially hazardous situation which, if not avoided, could result in death or serious injury.

Obey the following warnings:

 Read and understand all Warnings on this machine.  
Carefully read and understand the Assembly/Owner's Manual.

** DANGER**

Carefully read and understand the Assembly instructions. Read and understand the complete Manual. Keep the Manual for future reference.

** DANGER**

To reduce the risk of electrical shock or unsupervised usage of the equipment, always unplug this machine from the electrical outlet immediately after using and before cleaning.

** WARNING**

To decrease the risk of burns, electric shock, or injury to persons, read and understand the complete Assembly/Owner's Manual. Failure to follow these guidelines can cause a serious or possibly fatal electrical shock or other serious injury.

- Keep bystanders and children away from the product you are assembling at all times.
- Do not connect power supply to the machine until instructed to do so.
- The machine should never be left unattended when plugged in. Unplug from outlet when not in use, and before putting on or taking off parts.
- Before each use, examine the machine for damage to power cord, loose parts or signs of wear. Do not use if found in this condition. If purchased in US/Canada, contact Customer Service for repair information. If purchased outside US/Canada, contact your local distributor for repair information.
- Not intended for use by persons with medical conditions where those conditions may impact the safe operation of the treadmill or pose a risk of injury to the user.
- Do not drop or put objects into any opening of the machine.
- Never operate this treadmill with the air openings blocked. Keep the air openings free of lint, hair and the like.
- Do not assemble this machine outdoors or in a wet or moist location.
- Make sure assembly is done in an appropriate work space away from foot traffic and exposure to bystanders.
- Some components of the machine can be heavy or awkward. Use a second person when doing the assembly steps involving these parts. Do not do steps that involve heavy lifting or awkward movements on your own.
- Set up this machine on a solid, level, horizontal surface.
- Do not try to change the design or functionality of this machine. This could compromise the safety of this machine and will void the warranty.
- If replacement parts are necessary, use only genuine Nautilus replacement parts and hardware. Failure to use genuine replacement parts can cause a risk to users, keep the machine from operating correctly and void the warranty.
- Do not use until the machine has been fully assembled and inspected for correct performance in accordance with the Manual.
- Use this machine only for its intended use as described in this manual. Do not use attachments not recommended by the manufacturer.
- Do all assembly steps in the sequence given. Incorrect assembly can lead to injury or incorrect function.
- Connect this machine to a properly grounded outlet only (see Grounding or Earthing Instructions).
- Keep the power cord away from heat sources and hot surfaces.
- Do not operate where aerosol products are being used.
- To disconnect, turn all controls to the off position, then remove plug from outlet.
- **SAVE THESE INSTRUCTIONS.**

Before using this equipment, obey the following warnings:



**Read and understand the complete Manual. Keep the Manual for future reference.**

**Read and understand all warnings on this machine. If at any time the Warning labels become loose, unreadable or dislodged, replace the labels. If purchased in US/Canada, contact Customer Service for replacement labels. If purchased outside US/Canada, contact your local distributor for them.**

## **⚠ DANGER**

**To reduce the risk of electrical shock or unsupervised usage of the equipment, always unplug the power cord from the wall outlet and/or the machine and wait 5 minutes before cleaning, maintaining or repairing the machine. Place the power cord in a secure location.**

- Children must not be let on or near to this machine. Moving parts and other features of the machine can be dangerous to children.
- Not intended for use by anyone under 14 years of age.
- Consult a physician before you start an exercise program. Stop exercising if you feel pain or tightness in your chest, become short of breath, or feel faint. Contact your doctor before you use the machine again. Use the values calculated or measured by the machine's computer for reference purposes only.
- Before each use, examine this machine for damage to power cord, power receptacle, loose parts or signs of wear. Do not use if found in this condition. If purchased in US/Canada, contact Customer Service for repair information. If purchased outside US/Canada, contact your local distributor for repair information.
- Maximum user weight limit: 181 kg (400 lbs.). Do not use if you are over this weight.
- This machine intended for Home/Consumer or Studio/Institutional use. Studio/Institutional use is defined as settings where usage is less than 3 hours per day in non-dues-paying facilities --for example, condominiums, hotels and corporate gyms.
- Do not wear loose clothing or jewelry. This machine contains moving parts. Do not put fingers or other objects into moving parts of the exercise equipment.
- Always wear rubber soled athletic shoes when you use this machine. Do not use the machine with bare feet or only wearing socks.
- Set up and operate this machine on a solid, level, horizontal surface.
- Use caution when you step on and off the machine. Use the supplied foot support platforms for stability before walking on the moving belt.
- To prevent injury, stand on the foot support platforms before you start the machine or end a workout. Do not dismount the machine by standing on the moving Walking Belts and exiting off the rear of the machine.
- Disconnect all power before servicing this machine.
- Do not operate this machine outdoors or in moist or wet locations.
- Keep at least 0.5 m (19.7") on each side of the machine and 2 m (79") behind the machine clear. This is the recommended safe distance for access and passage around and emergency dismounts from the machine. Keep third parties out of this space when machine is in use.
- Do not over exert yourself during exercise. Operate the machine in the manner described in this manual.
- Perform all regular and periodic maintenance procedures recommended in the manual.
- Read, understand, and test the Emergency Stop Procedure before use
- Keep the walking belt clean and dry.
- Do not drop or put objects into any opening of the machine.
- Do not stand on machine motor cover or front trim cover.
- Keep power cord away from heat source and hot surfaces.
- This machine must be connected to an appropriate, dedicated electrical circuit. Nothing else must be connected to the circuit.
- Always connect the power cord to a circuit capable of handling 15 amperes for 110V AC or 10 amperes for 220-240V AC with no other loads applied.
- Connect this machine to a correctly grounded outlet; consult a licensed electrician for assistance.
- Do not operate where aerosol (spray) products are being used or where oxygen is being administered.
- Do not let liquids touch the electronic controller. If it does, the controller must be inspected and tested for safety by an approved technician before it can be used again.
- The electrical wiring for the residence in which the machine will be used must obey the applicable local and provincial requirements.
- Exercise on this machine requires coordination and balance. Be sure to anticipate that changes in belt speed and incline angle of deck can occur during workouts, and be attentive in order to avoid loss of balance and possible injury.
- A machine should never be left unattended when plugged in. Unplug from outlet when not in use, and before putting on or taking off parts.
- Use this machine only for its intended use as described in this manual. Do not use attachments not recommended by the manufacturer.



- This appliance is not intended for use by persons with reduced physical, sensory or mental capabilities, or lack of knowledge, unless they have been given supervision or instruction concerning use of the appliance by a person responsible for their safety. Keep children under the age of 14 away from this machine.
- When the machine is put in a Studio/Institutional environment, it can only be used in areas where access and control of the machine are managed and supervised by approved staff. The degree of supervision and oversight depends among other things on the specific setting in which the machine is placed, security of that environment, and familiarity of the users with the equipment. Because others may have used the machine previously, make sure that all parts and hardware are fully tightened and secured.
- Children should be supervised to ensure that they do not play with the appliance.
- **SAVE THESE INSTRUCTIONS.**

## Safety Warning Labels and Serial Number

### CAUTION

Risk of Injury to Persons - To Avoid injury, use extreme caution when stepping onto or off of a moving belt. Read instruction manual before using.

### WARNING!

- Injury or death is possible if caution is not used while using this machine.
- Keep children and pets away.
- Read and follow all warnings on this machine.
- Refer to the Owner's Manual for additional warnings and safety information.
- The heart rate displayed is an approximation and should be used for reference only.
- Not intended for use by anyone under 14 years of age.
- The maximum user weight for this machine is 400 lbs (181 kg).
- Consult a physician prior to using any exercise equipment.
- REMOVE SAFETY KEY WHEN NOT IN USE, AND STORE OUT OF REACH OF CHILDREN.

(This label is only available on the Bowflex™ Treadmill 22 machine in English and French Canadian.)



**WARNING!** Keep young children away from this machine at all times. Contact with the moving surface may result in severe friction burns.

(This label is only available on the Bowflex™ Treadmill 56 machine in English.)

### WARNING!

Heart rate monitoring systems may be inaccurate. Over exercising may result in serious injury or death. If you feel faint, stop exercising immediately.

(This label is only available on the Bowflex™ Treadmill 56 machine in English.)

Console Serial Number Label

Serial Number and Product Specification



### WARNING!

- HAZARDOUS VOLTAGE.
- Contact may cause electrical shock or burn.
  - Turn off and lock out power before servicing.



### WARNING!

- Moving parts can crush and cut.
- Keep guards in place.
- Lock out power before servicing.

(These labels are only available in English and French Canadian.)



### WARNING!

Keep hands and feet away.

(This label is only available in English and French Canadian.)

## Grounding Instructions (for a 120V AC system )

This product must be grounded. If it should malfunction or break down, grounding provides a path of least resistance for electric current to reduce the risk of electric shock. This product is equipped with a cord having an equipment-grounding conductor and a grounding plug. The plug must be plugged into an appropriate outlet that is properly installed and grounded in accordance with all local codes and ordinances.

### **⚠ DANGER**

**Improper connection of the equipment-grounding conductor can result in a risk of electric shock. Check with a qualified electrician or service person if you are in doubt as to whether the product is properly grounded. Do not modify the plug provided with the product – if it will not fit the outlet, have a proper outlet installed by a qualified electrician.**

If you connect the machine to an outlet with GFI (ground fault interrupt) or AFI (arc fault interrupt), machine operation can cause the circuit to trip.

**⚠ This machine is for use on a nominal 120-V circuit, and has a grounding plug that looks like the plug illustrated below. A temporary adapter that looks like the adapter illustrated may be used to connect this plug to a 2-pole receptacle as shown if a properly grounded outlet is not available.**

The temporary adapter should be used only until a properly grounded outlet can be installed by a qualified electrician. The tab for the grounding screw must be connected to a permanent ground such as a properly grounded outlet box cover. Whenever the adapter is used, it must be held in place by a metal screw.

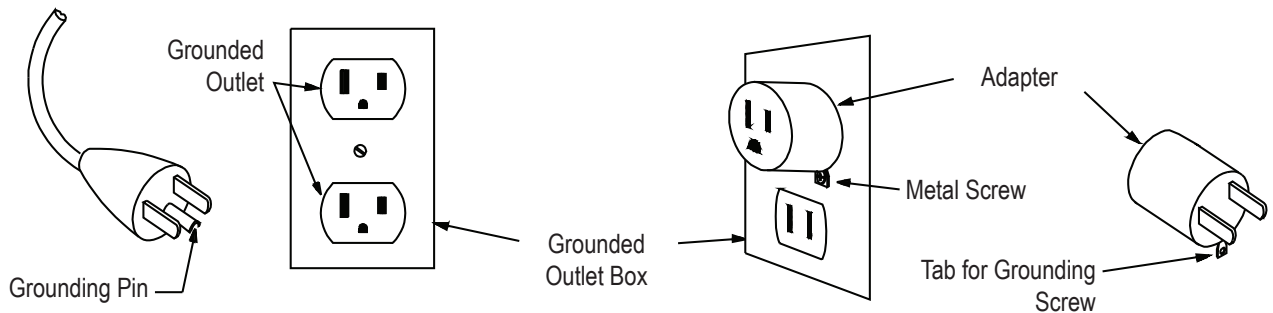

## Earthing Instructions (for a 220-240V AC system )

This product must be electrically earthed. If a malfunction occurs, correct earthing decreases the risk of electric shock. The power cord is equipped with an equipment-earthing conductor, and must be connected to an outlet that is properly installed and earthed.

### **⚠ DANGER**

**The electrical wiring must comply with all applicable local and provincial standards and requirements. Incorrect connection of the equipment-earthing conductor can result in a risk of electric shock. Consult a licensed electrician if you are not sure that the machine is correctly earthed. Do not change the plug on the machine – if it does not fit the outlet, have a correct outlet installed by a licensed electrician.**

If you connect the machine to an outlet with RCBO (Residual-Current circuit Breaker with Overload protection), machine operation can cause the circuit to trip. A Surge Protector Device is recommended to protect the machine.

**⚠ If a Surge Protector Device (SPD) is used with this machine, be sure that it matches the power rating of this equipment (220-240V AC). Do not connect other appliances or devices to the surge protector in combination with this machine.**

**Make sure that the product is connected to an outlet having the same configuration as the plug. Use the appropriate adapter supplied with this product.**

## Emergency Stop Procedure

The Treadmill machine is equipped with a Safety Key that can prevent serious injury, as well as prevent children from playing with and/or being injured on the machine. If the Safety Key is not correctly inserted into the Safety Key Port, the belt will not operate.

 **Always attach the Safety Key Clip to your clothing during your workout.**

**When you use the machine, only remove the Safety Key in an emergency. When the key is removed while the machine is in operation, it will stop quickly, which could cause the loss of balance and possible injury.**

**For safe storage of the machine, and to prevent unsupervised operation of the machine, always remove the Safety Key and disconnect the power cord from the wall outlet and the AC input. Place the power cord in a secure location.**

The Console will display, “ Safety Key Disconnected. To do a workout, insert the Safety key. “, when there is a Safety Key fault. The Treadmill machine will not start a Workout, or will end and clear an active Workout, when the Safety Key is removed. Inspect the Safety Key and be sure it is connected to the Console correctly.

# Specifications / Before Assembly

<b>Power Requirements:</b>	<b>120V</b>	<b>220V</b>
Operational Voltage:	110-127V AC, 60Hz	220V - 240V AC, 50Hz
Operating Current:	15 A	8 A

Heart Rate Armband: 1 Lithium Polymer battery (not replaceable)

<b>Maximum User Weight:</b>	181 kg (400 lbs)
<b>Total Surface Area (footprint) of equipment:</b>	21688 cm <sup>2</sup>
<b>Maximum Inclined Deck Height:</b>	46.2 cm (18.2 inches)
<b>Machine Weight:</b>	approx. 152.4 kg (336 lbs)

**Sound Emission:** Less than 70 db average without load. Noise emission under load is higher than without load.

**This product complies with the European Radio Equipment Directive 2014/53/EU**



DO NOT dispose of this product as refuse. This product is to be recycled. For proper disposal of this product, please follow the prescribed methods at an approved waste center.

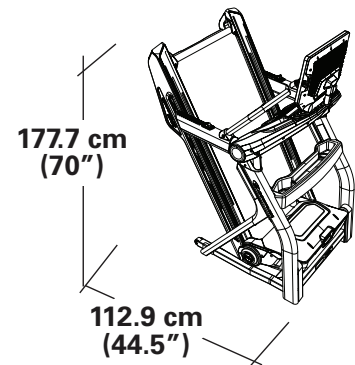
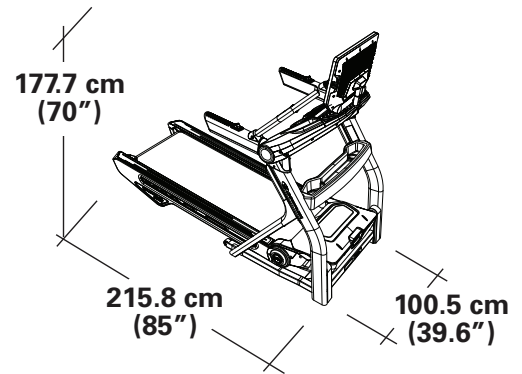

## Before Assembly

Select the area where you are going to set up and operate your machine. For safe operation, the location must be on a hard, level surface. Allow a minimum workout area of 200.5 cm x 416 cm (79" x 164"). Be sure that the workout space you are utilizing has adequate height clearance, taking into consideration the height of the user and the maximum incline of the machine.

## Basic Assembly

Follow these basic points when you assemble your machine:

- Read and understand the "Important Safety Instructions" before assembly.
- Collect all the pieces necessary for each assembly step.
- Using the recommended wrenches, turn the bolts and nuts to the right (clockwise) to tighten, and the left (counterclockwise) to loosen, unless instructed otherwise.
- When attaching 2 pieces, lightly lift and look through the bolt holes to help insert the bolt through the holes.
- The assembly requires 2 people.
- Do not use any power tools for assembly.

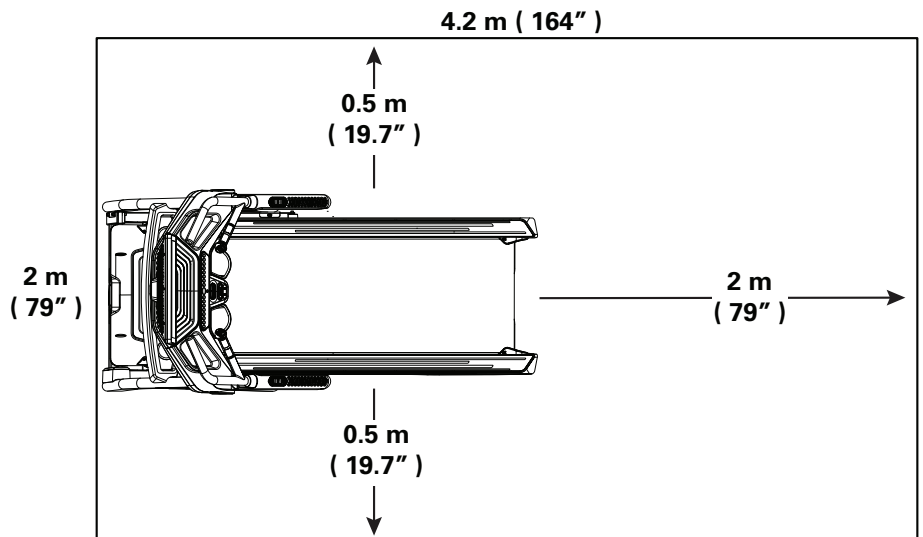

## Machine Mat

The Bowflex™ Machine Mat is an optional accessory that helps keep your workout area clear and adds a layer of protection to your floor. The rubber machine mat provides a non-slip, rubber surface which limits static discharge and reduces the possibility of display errors. If possible, put your Bowflex™ Machine Mat in your selected workout area before you begin assembly.

To order the optional machine mat, contact Customer Service (if purchased in US/Canada) or your local distributor (if purchased outside US/Canada).

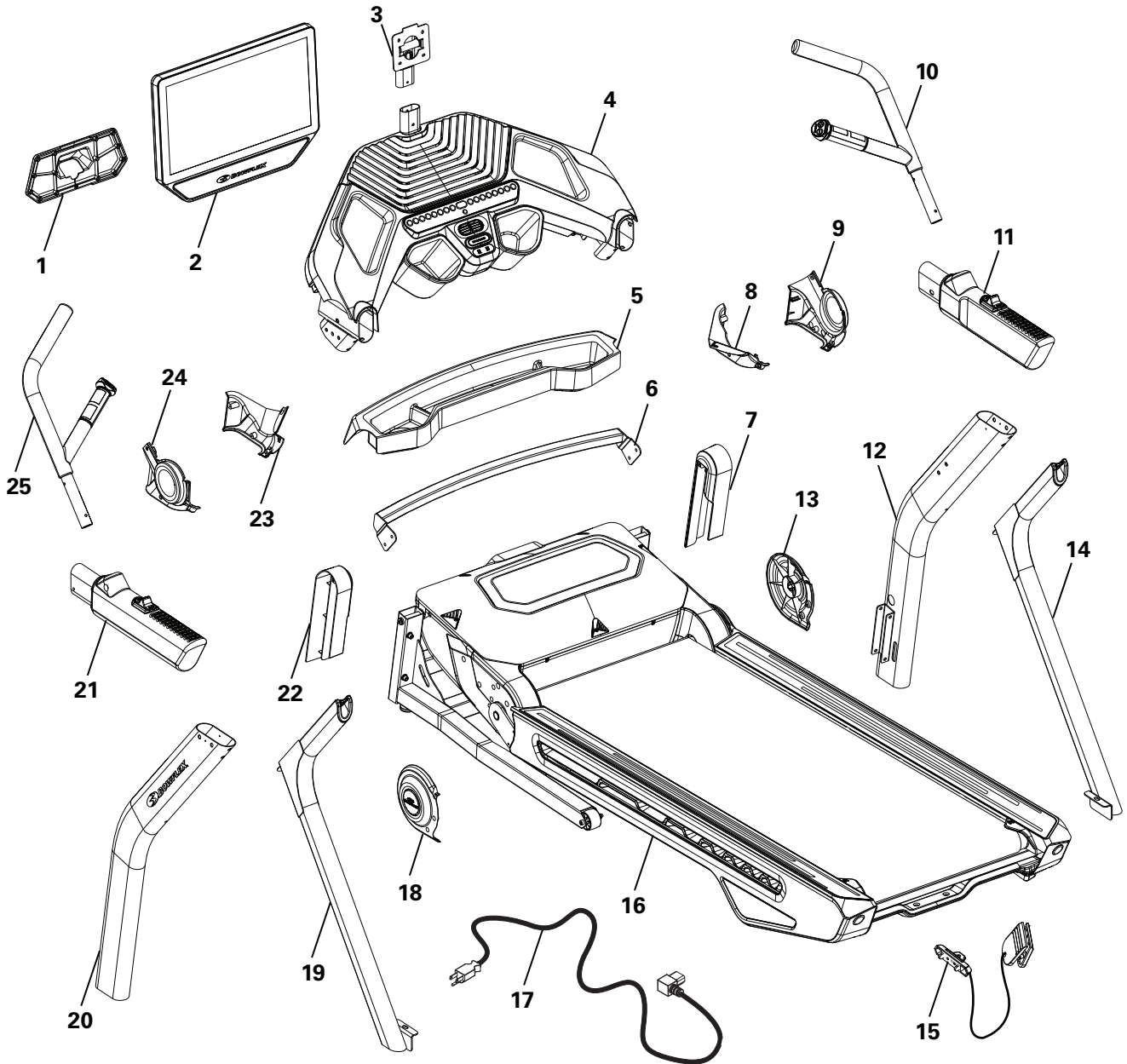

Item	Qty	Description	Item	Qty	Description
1	1	Console Rear Cover	14	1	Upright Support, Right
2	1	Console Assembly	15	1	Safety Key
3	1	Console Mast	16	1	Base Assembly
4	1	Console Base Assembly	17	1	Power Cord
5	1	Tray	18	1	Pivot Cover, Left
6	1	Crossbar	19	1	Upright Support, Left
7	1	Base Shroud, Right	20	1	Upright, Left
8	1	Inner Junction Cover, Right	21	1	Handlebar Assembly, Left
9	1	Outer Junction Cover, Right	22	1	Base Shroud, Left
10	1	Upper Handlebar Assembly, Right	23	1	Inner Junction Cover, Left
11	1	Handlebar Assembly, Right	24	1	Outer Junction Cover, Left
12	1	Upright, Right	25	1	Upper Handlebar Assembly, Left
13	1	Pivot Cover, Right	26	1	Document Kit / Hardware Card (not shown)

# Hardware / Tools / Assembly

**!** When moving the Deck Assembly, be sure to grasp the sides of it. Do not grasp the Walking Deck Release Button. Pressing the Walking Deck Release Button releases the locking mechanism on the hydraulic lift.



## Hardware

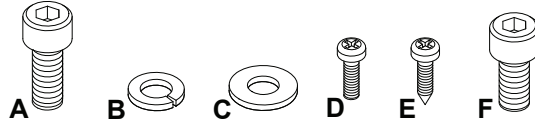

Item	Qty	Description	Item	Qty	Description
A	32	Socket Hex Head Screw, M8x1.25x16 Black	D	4	Pan Phillips Head Screw, M4x10 Black
B	34	Lock Washer, M8x14.8 Black	E	8	Pan Phillips Head Screw, M4.2x13 Black
C	34	Flat Washer, M8x18 Black	F	2	Socket Hex Head Screw, M8x1.25x12 Black

**Note:** Select pieces of Hardware have been provided as spares on the Hardware Card. Be aware that there may be remaining Hardware after the proper assembly of your machine.

## Tools

Included



6mm



#2

## **!** WARNING

DO NOT CUT the Shipping Strap on the Base Assembly until it has been placed face up as shown in the appropriate work space.

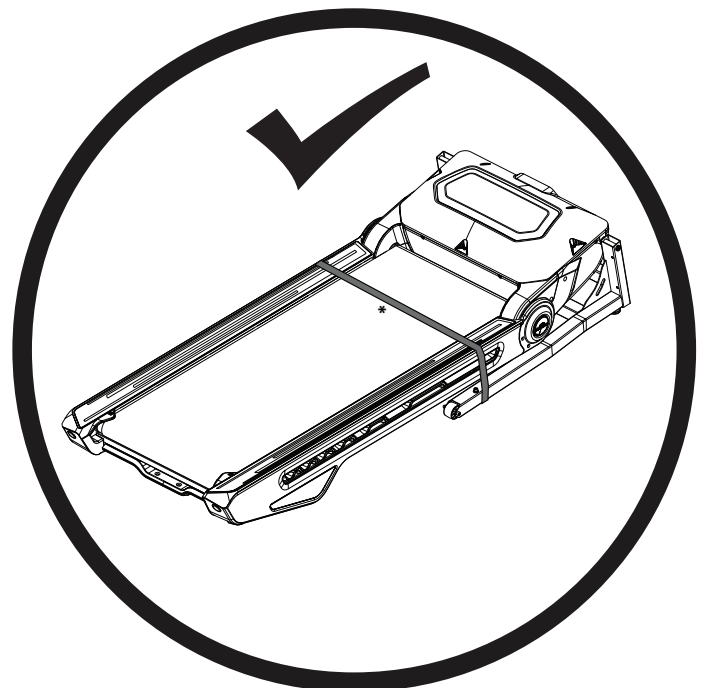
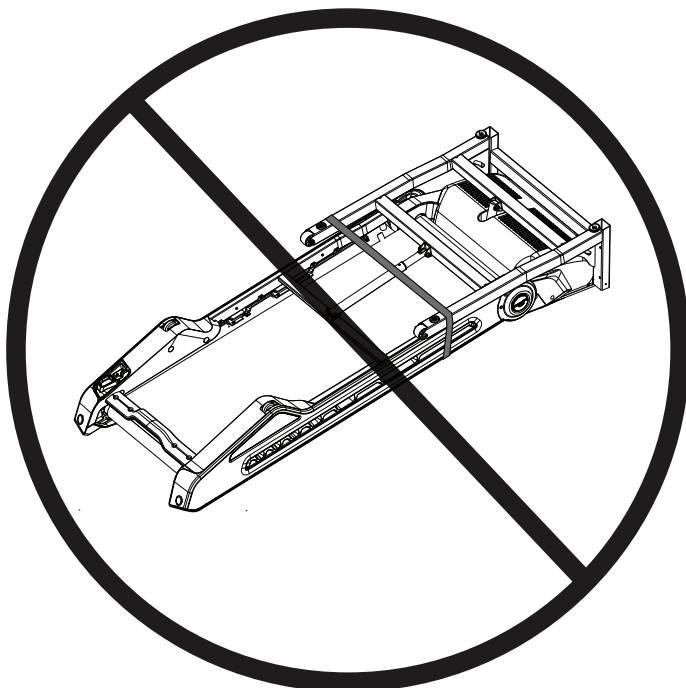



# 1. Attach the Uprights to the Base Assembly, and then Connect the Cables from the Base Assembly to the Right Upright

Note: Do not crimp cables. Do not fully tighten Hardware until instructed.

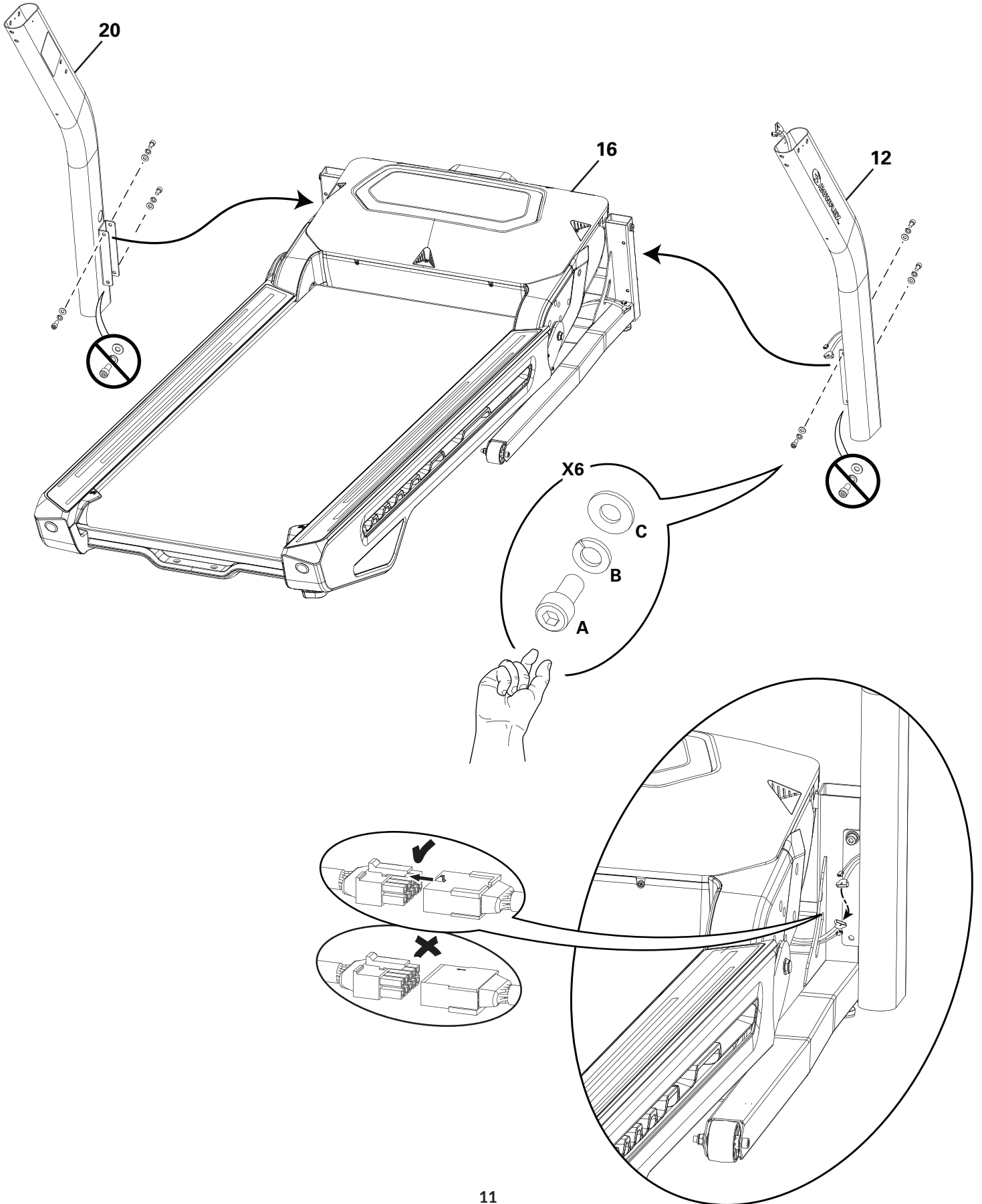

## 2. Attach the Crossbar and Pivot Shrouds to the Frame Assembly

**Note:** Do not crimp cables. Do not fully tighten the Crossbar hardware until instructed. A right ("R") decal has been applied to the right side of the Crossbar to assist with assembly.

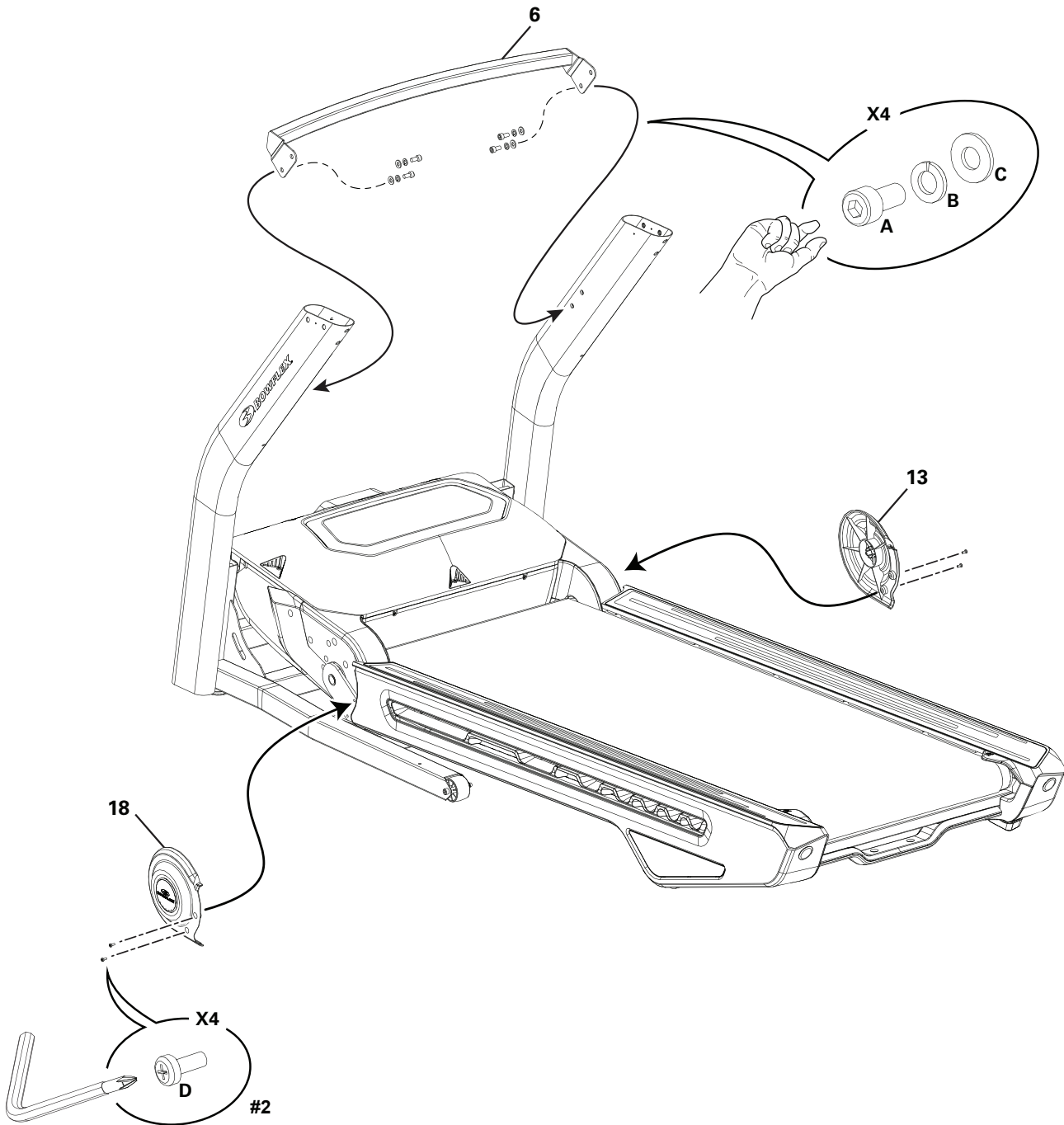

### 3. Attach the Console Base Assembly and Connect the Cables

**!** Some components of the machine can be heavy or awkward. Use a second person when doing the assembly steps involving these parts. Do not do steps that involve heavy lifting or awkward movements on your own.

**Note:** Do not crimp the Cables. Be sure that the Cables from the Right Upright are toward the front of the machine. Do not fully tighten Hardware until instructed.

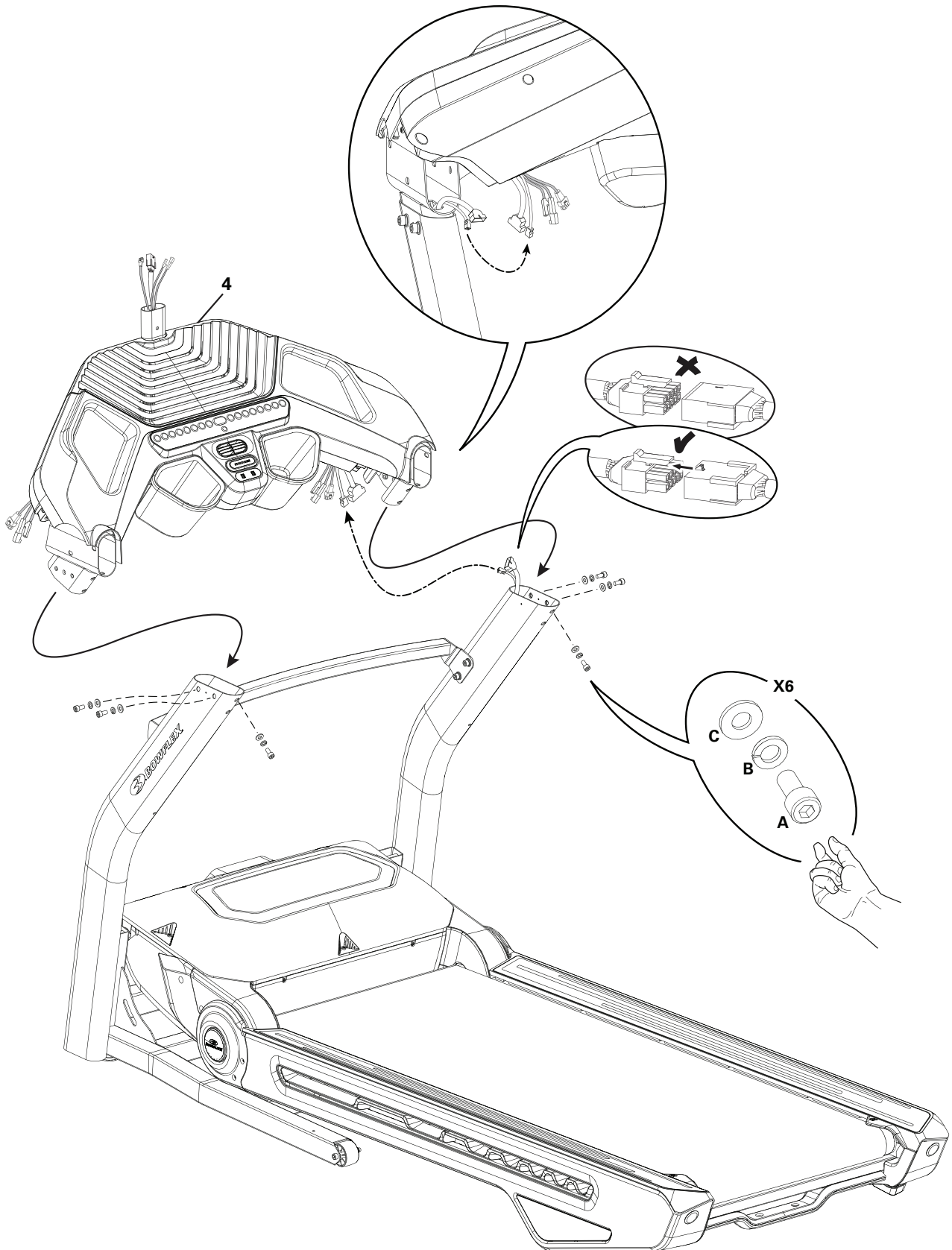

#### 4. Attach the Upright Supports to the Frame Assembly, and Fully Tighten All Hardware

**Note:** Loosely install hardware (\*\*\*) first. With all of the hardware started, tighten the hardware in the order of (\*\*\*), (\*\*), and (\*). Then fully tighten all Hardware from previous steps.

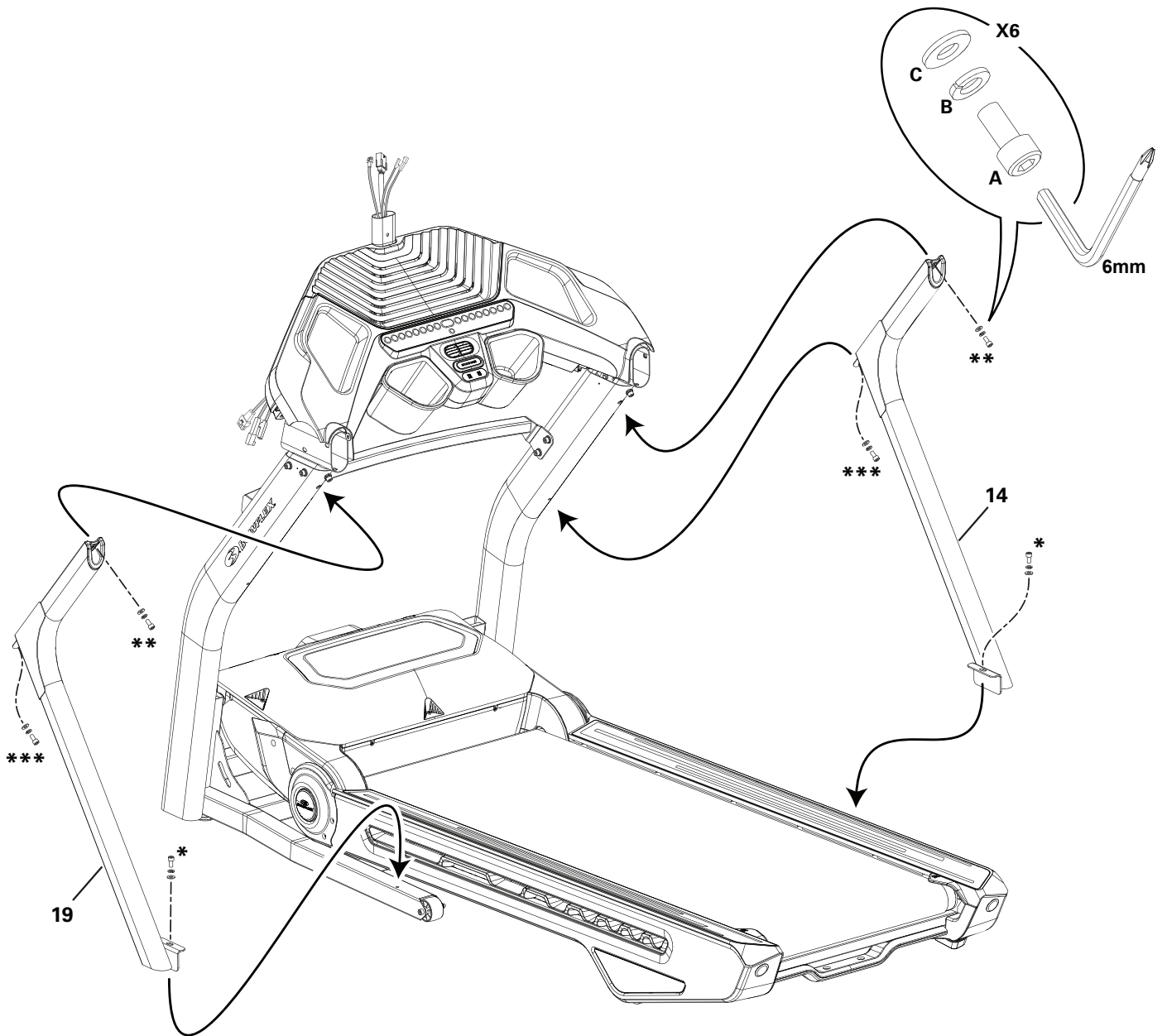

## 5. Route the Cables through the Console Mast, and then Attach the Console Mast to the Frame Assembly

Note: Do not crimp the Cables.

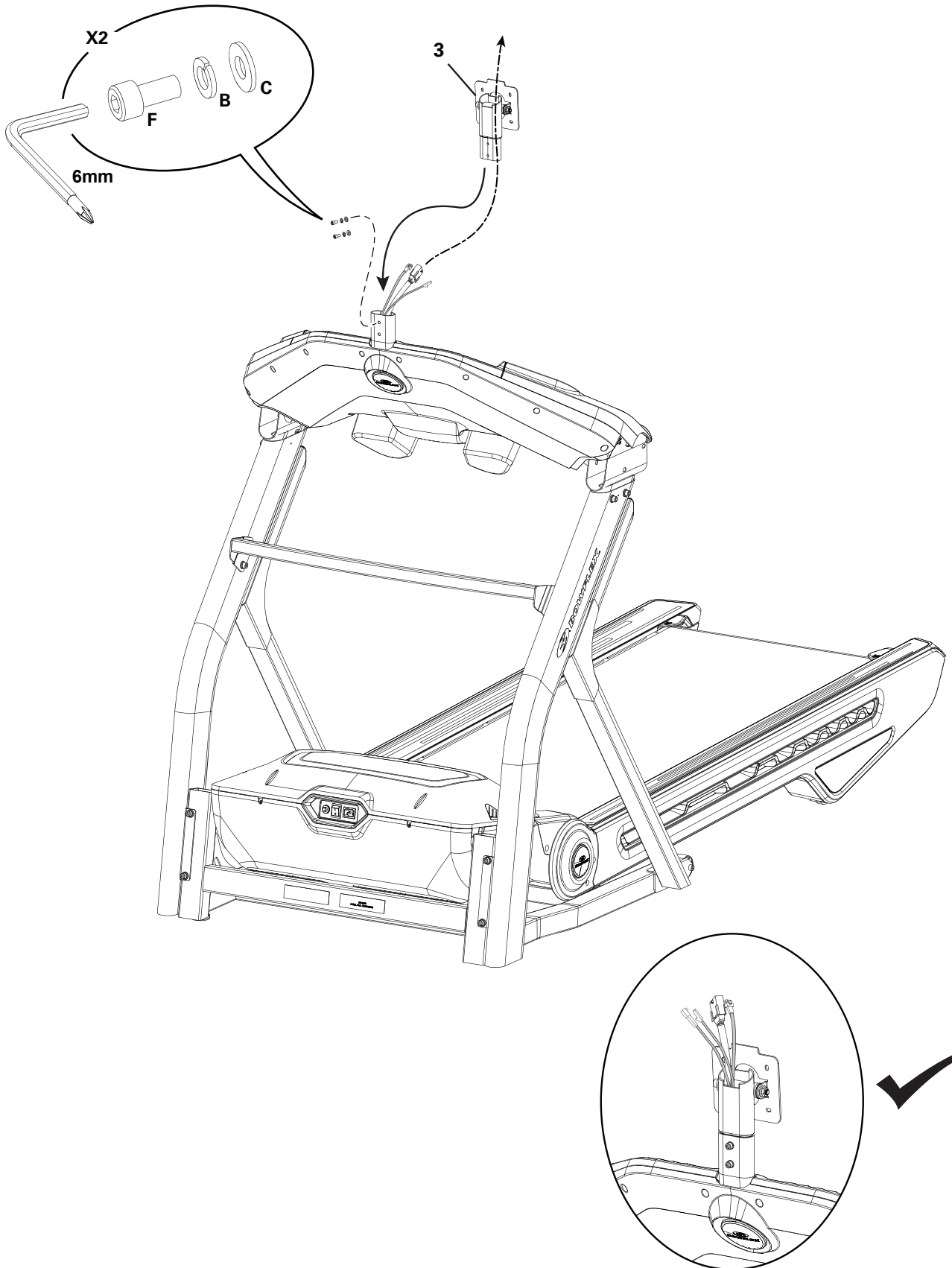

## 6. Remove the Console Rear Cover and then the Hardware from the Console Assembly

*NOTICE:* Do not cut or crimp the Cables. \* Hardware is not supplied on the Hardware Card.

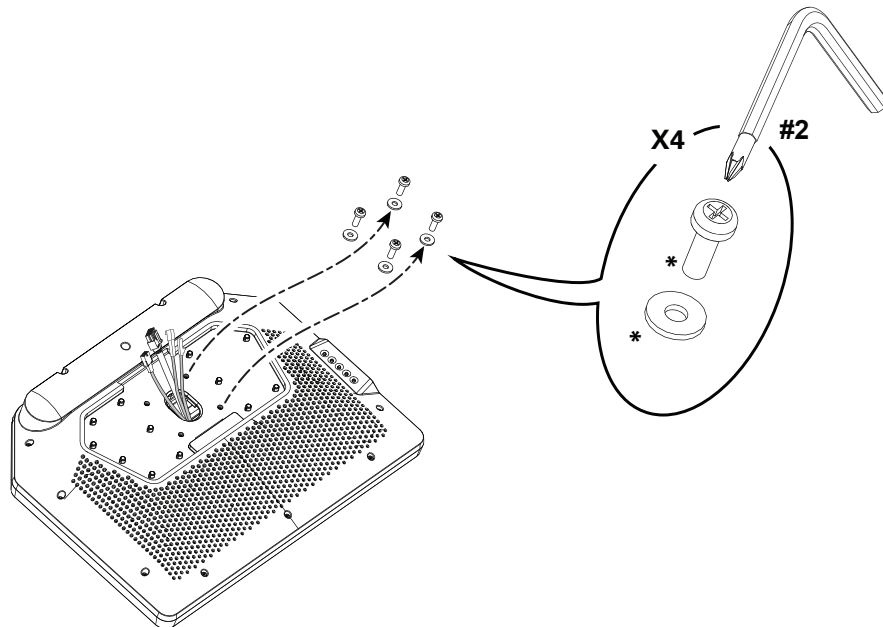
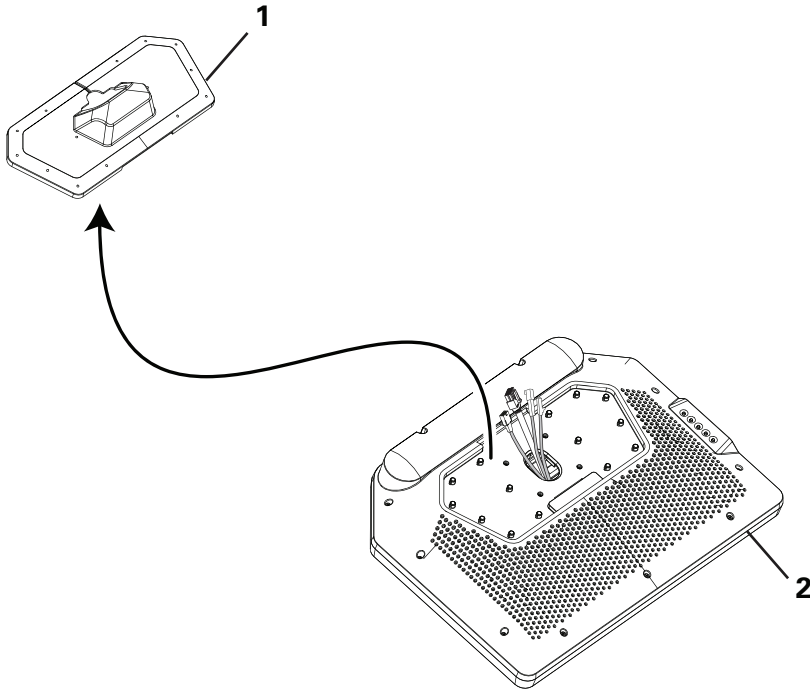



## 7. Route the Console Cables and Attach the Console Assembly

**NOTICE:** Do not cut or crimp the Cables. Each Cable Connector has a corresponding end connector with that many openings. Be sure to fully connect the cable connectors. \* Hardware is not supplied on the Hardware Card.

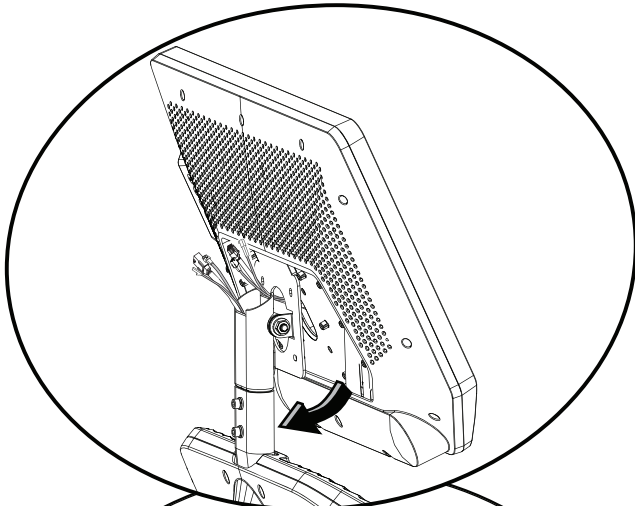
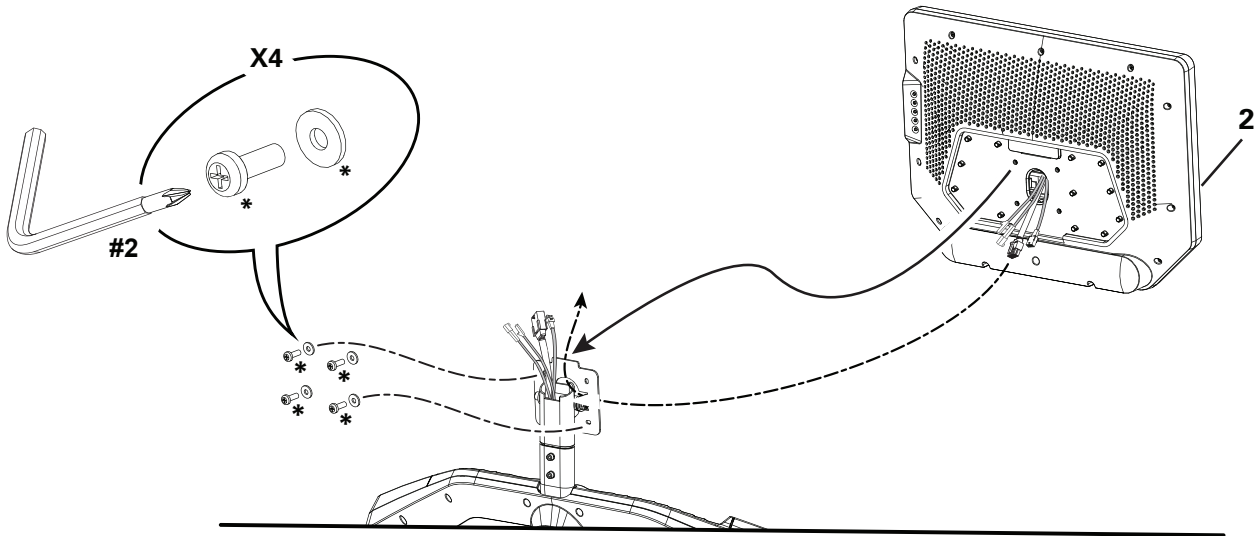

- a. Place the Console onto the Console Mast and route the Cables through and out of the Console Mast

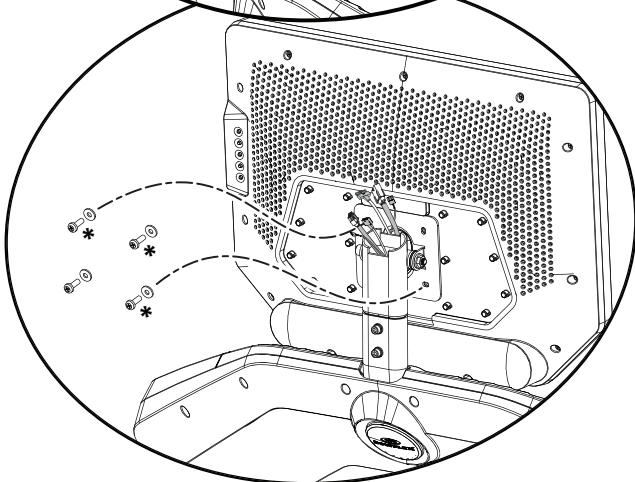

- b. Fully pivot the Console Assembly downward and secure it to the Console Mast.

**Note:** Do not crimp the Cables.

## 7. Route the Console Cables and Attach the Console Assembly (continued)

c. Connect the Cables.

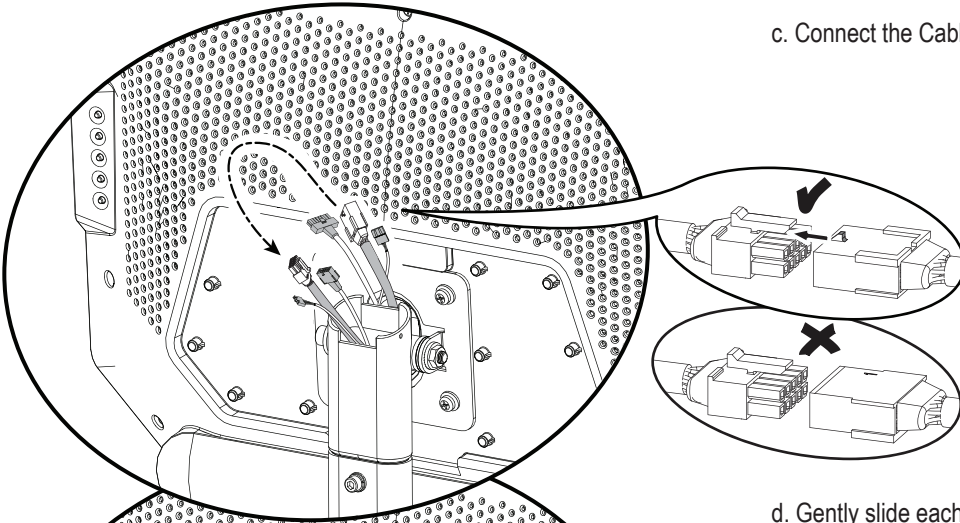

d. Gently slide each of the Connectors and their Cables down into the Console Mast in the following order:

1. White Connector
2. Large Black Connector
3. Small Black Connector

**Note:** Push the Connectors into the Console Mast until the Cable from the Console Assembly is taut, or not loose.

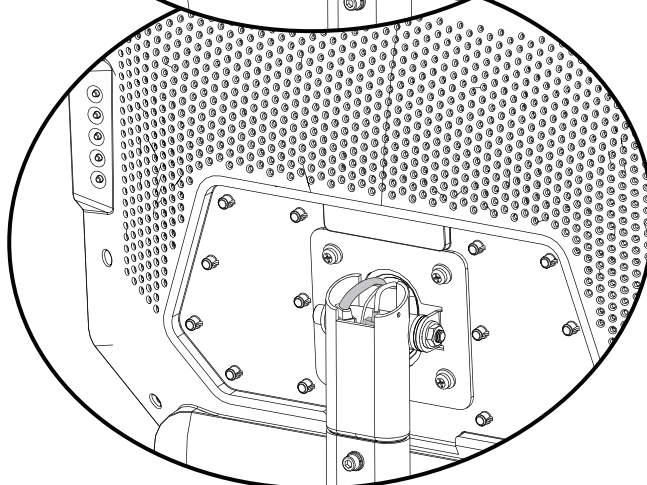
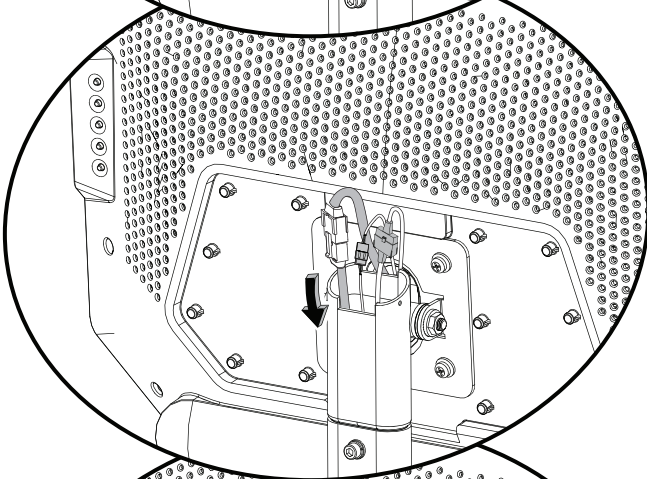

## 8. Attach the Side Handlebars and Connect the Cables

Note: Do not crimp the Cables. A right ("R") and left ("L") decal have been applied to these parts to assist with assembly.

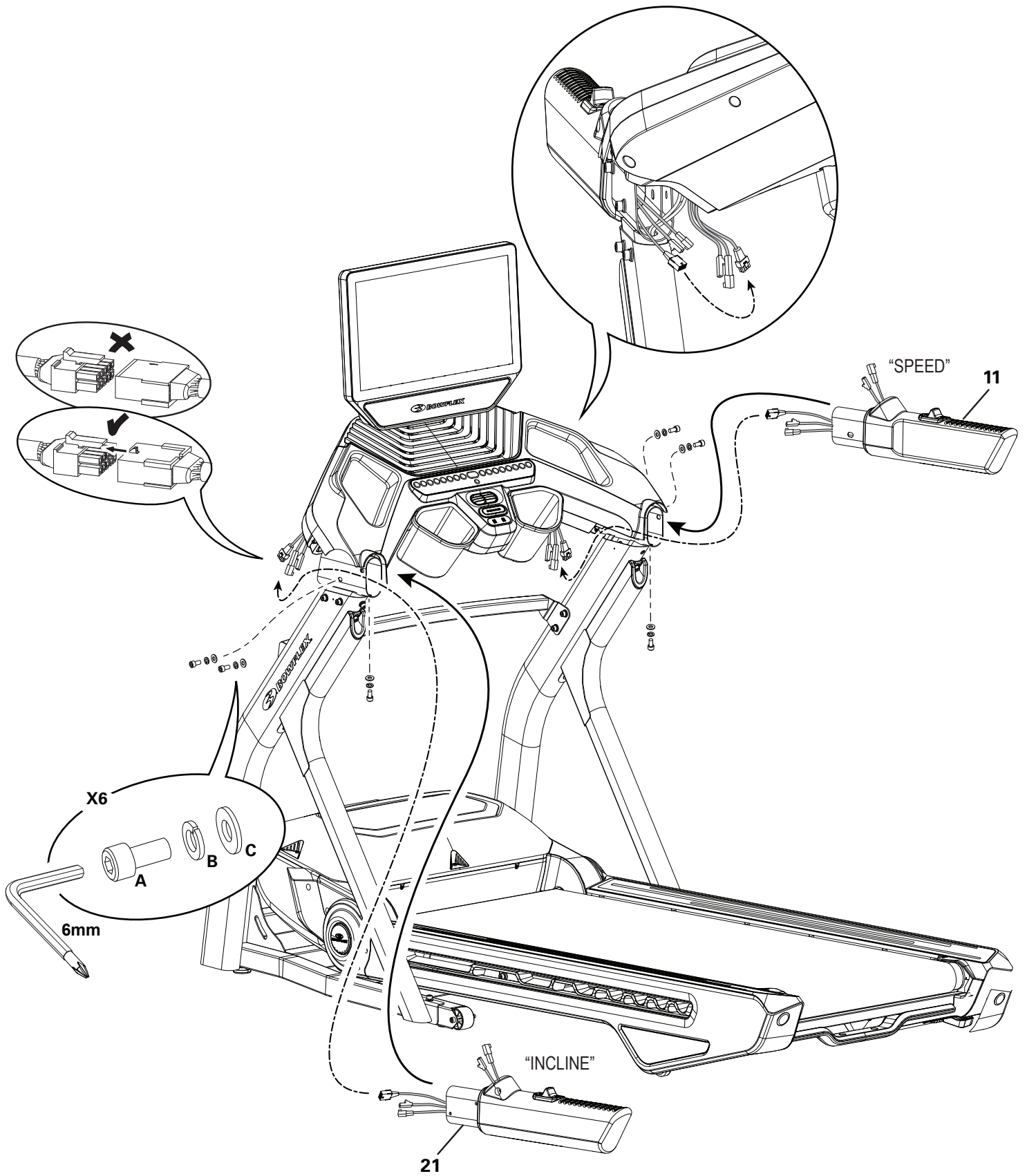

## 9. Connect the Cables and Insert the Upper Handlebars

**Note:** Do not crimp the Cables. After connecting the Cables, be sure to push the Connectors up into the Upper Handlebars. This will protect the Cables during assembly. Be sure that the Upper Handlebars are fully inserted. A right (" R ") and left (" L ") decal have been applied to these parts to assist with assembly.

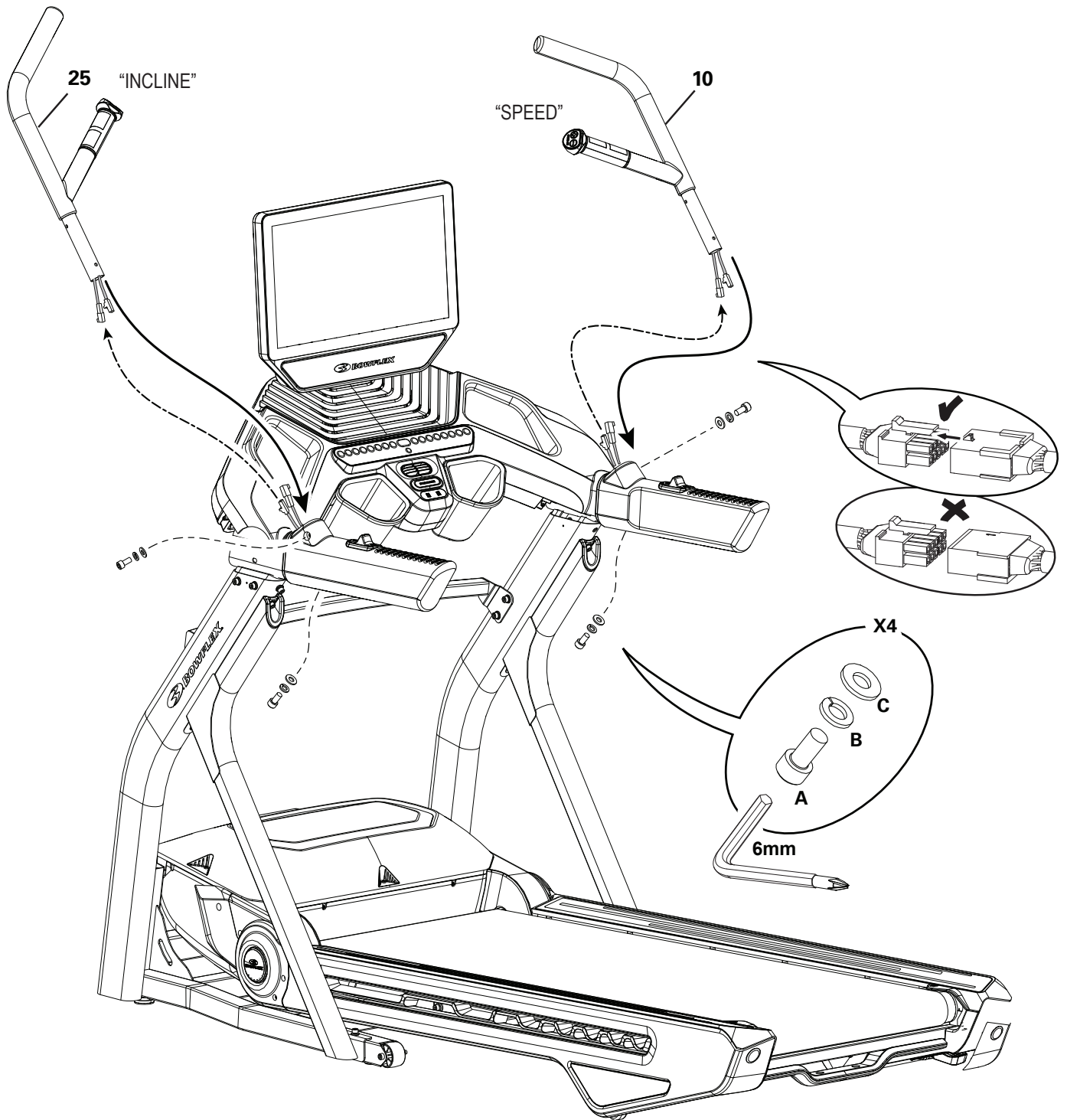

## 10. Attach the Base Shrouds and Outer Junction Covers to the Frame Assembly

**Note:** Be sure that the Right Base Shroud hides the Cable Connectors. If necessary, push the Cable further into the Right Upright.

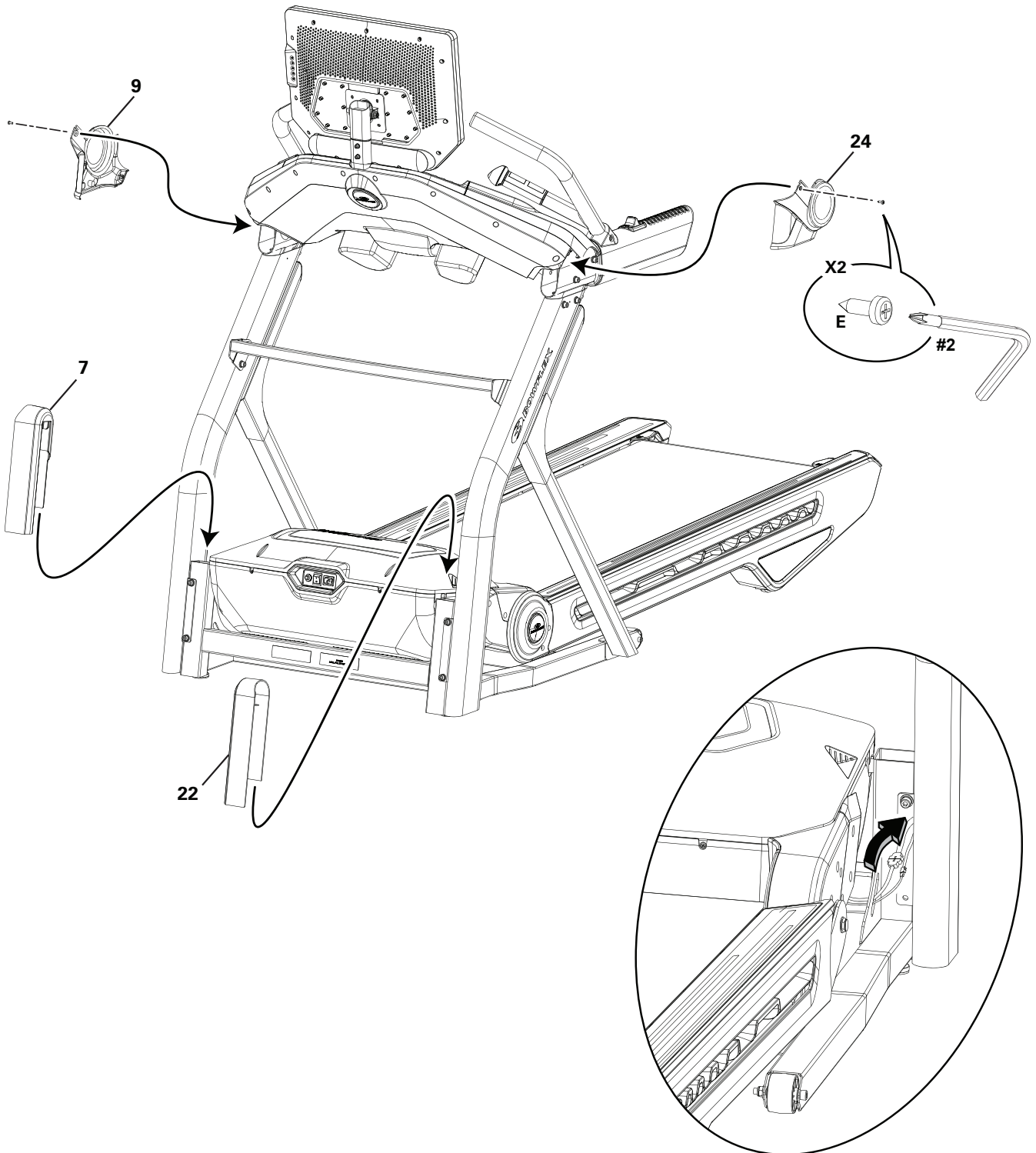



## 11. Attach the Inner Junction Covers to the Frame Assembly

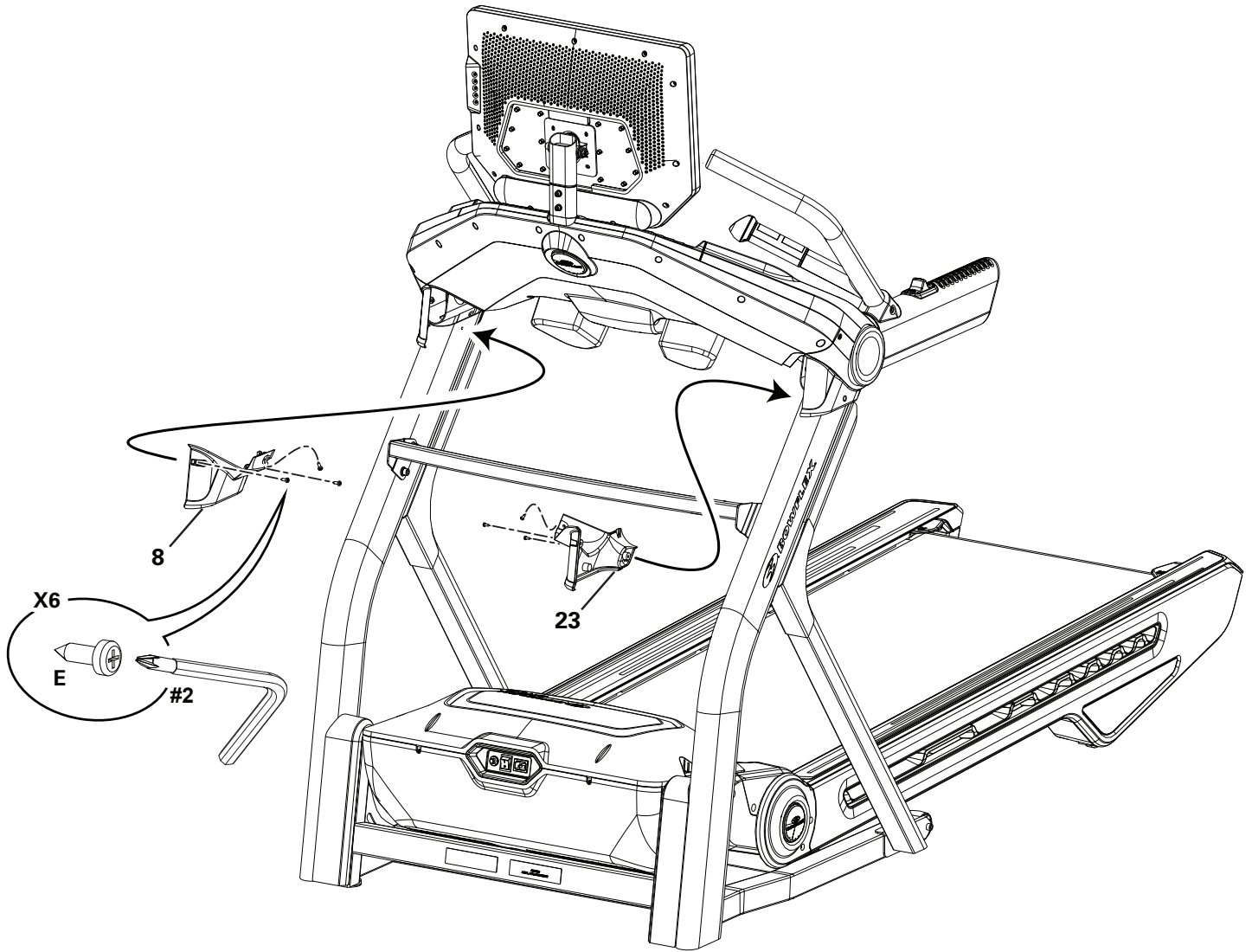



## 12. Attach the Crossbar Tray to the Frame Assembly

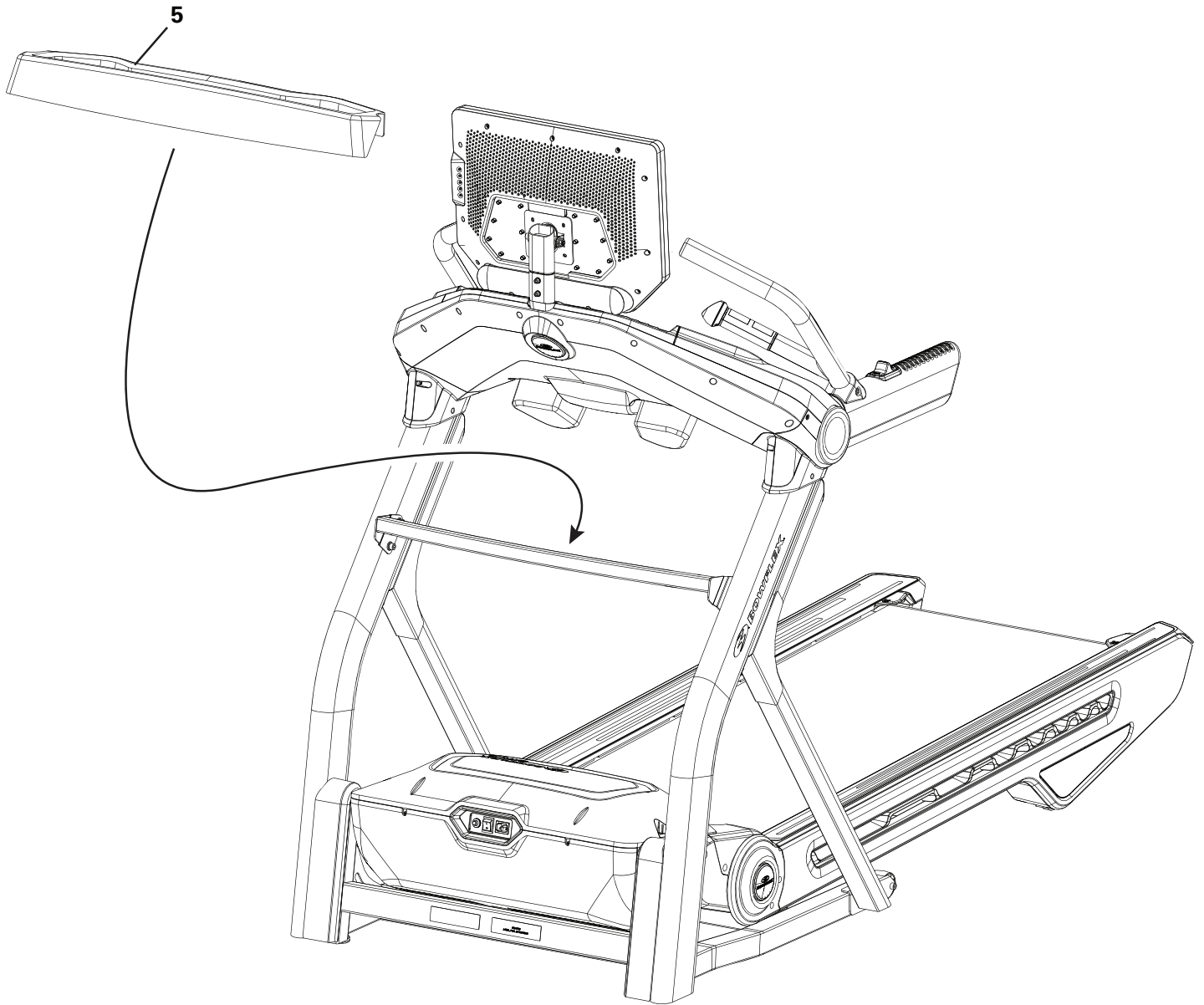

### 13. Attach the Console Rear Cover to the Frame Assembly

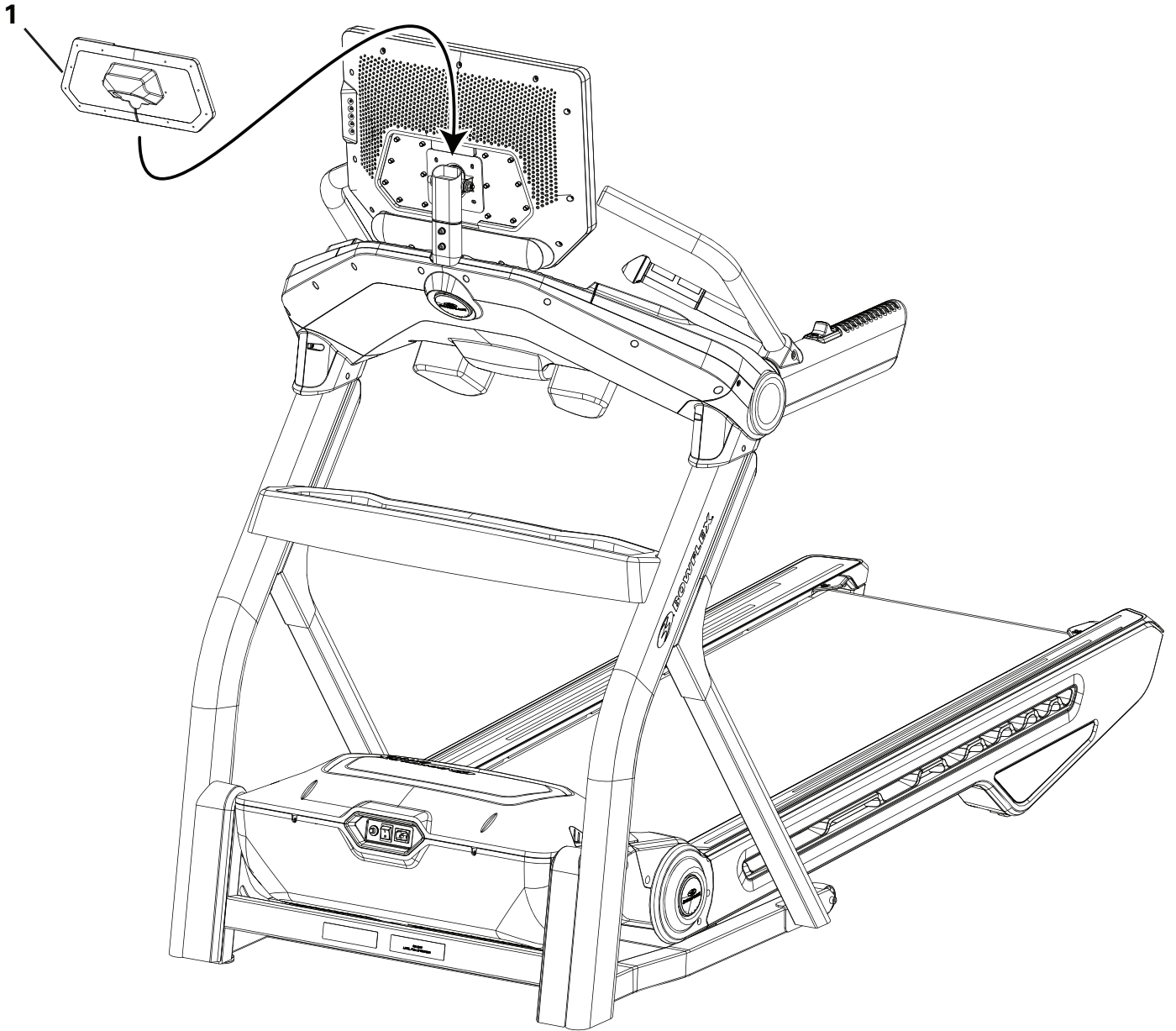

## 14. Connect the Power Cord and Safety Key to the Frame Assembly

 Connect this machine to a properly grounded outlet only (see Grounding/Earthing Instructions).

**Note:** When ready to operate the machine, be sure to turn on the power with the Power Switch.

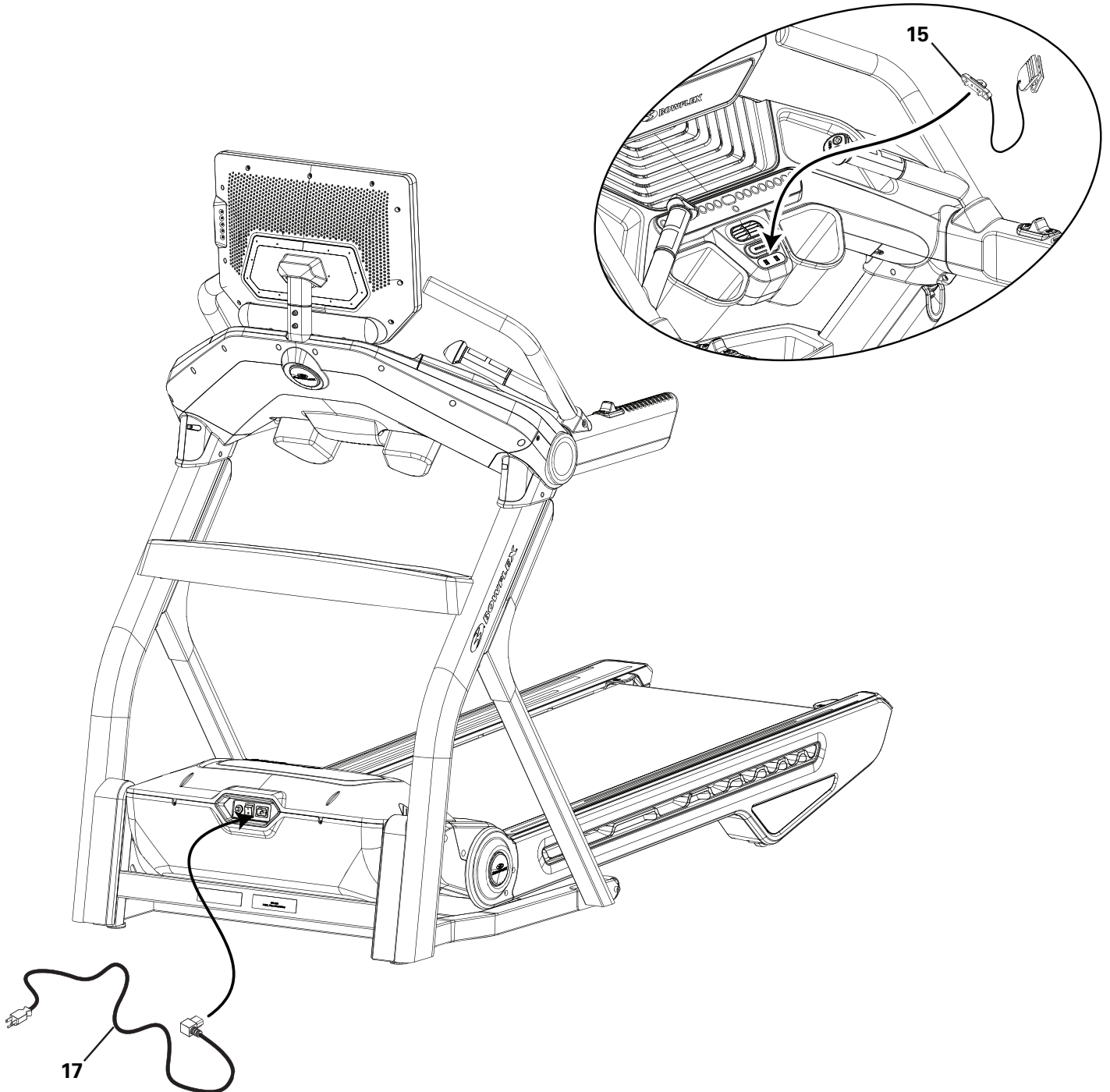

## 15. Set Up Your Machine

- a. With the machine plugged into a functioning wall outlet, the machine will start up and the red Status LED will activate.

**Note:** The Console may go to sleep if it does not receive any input. Touch the screen of the Console to wake up the machine.

- b. The machine will activate and display the Welcome - Connect Wifi screen. Tap on Connect.

**Note:** A Wifi connection is required to use your Bowflex™ machine. If you do not have a Wifi connection available, contact your Bowflex™ Representative or your local distributor immediately for further assistance.

- c. The Console will display the list of available Wifi connections. Tap on the desired Wifi connection, and enter the password. Tap on Connect.

- d. The Console will test and connect to the Wifi connection.

If the Console displays an Update Available screen, tap on the Agree button. The Console will update the software.

- e. With a Wifi connection established, tap on Back.

- f. Tap on Get Started.

- g. The Console will display the options screen. Choose Log In or Create Account. Follow the prompts to register your new fitness machine. When registration is completed, your fitness machine is now ready for use.

**Note:** The Bowflex™ machine must be registered using a Wifi connection. Once the initial registration and configuration is completed, the machine can be operated without a Wifi connection. However, only the basic workouts and functions will be available for use. All coaching, custom workouts, Explore The World™ virtual outdoor immersive runs and trainer lead workout videos are only available through a Wifi connection with a JRNY™ membership\*.

- h. The Console will display the Just for You screen. The screen will prompt you to do your Fitness Assessment workout to get a custom workout\*. You can go to the Learn tab for more information about your options.

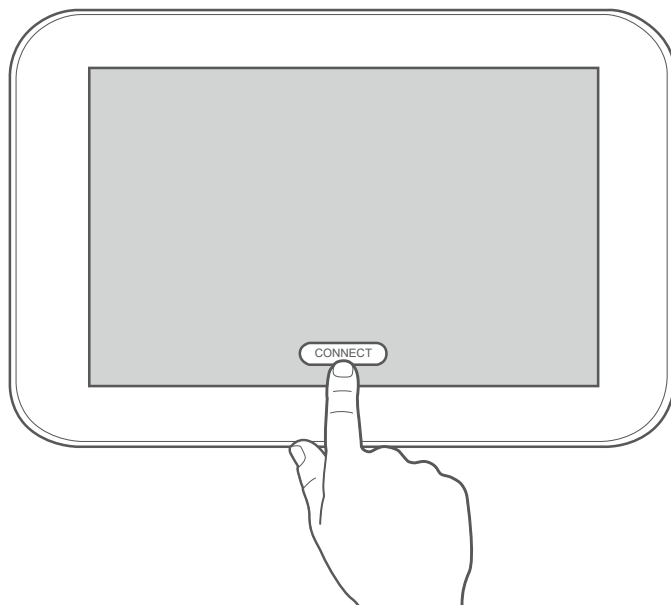

## 16. Final Inspection

Inspect your machine to ensure that all fasteners are tight and components are properly assembled.

**Note:** Remove any protective covers from the face of the Console.

Be sure to record the serial number in the field provided at the front of this manual.

**⚠ Do not use until the machine has been fully assembled and inspected for correct performance in accordance with the Owner's Manual.**

\* A JRNY™ membership is required for the JRNY™ experience – see [www.bowflex.com/jrny](http://www.bowflex.com/jrny) for details. For United States and Canada customers, you can obtain a JRNY™ membership by calling 800-269-4126 or visiting [www.bowflex.com/jrny](http://www.bowflex.com/jrny). Where available (including the United States), you can also obtain a JRNY™ membership by downloading the JRNY™ app onto your phone or tablet and signing up within the downloaded app. JRNY™ memberships may not be available in all countries.

## Moving and Storing the Machine

**!** The machine can be moved by one or more persons. Use caution when you move the machine. The treadmill is heavy and can be awkward. Make sure that your own physical strength is capable of moving the machine. Use a second person if necessary.

1. Before the machine can be moved, inspect the Walking Deck to be sure that the Incline setting is at “-5”. If necessary, adjust the Incline setting to “-5”.

**Note:** For the smallest stored machine footprint, be sure that the Incline setting is at “-5”.

**!** Be sure the area below the machine is clear before adjusting the incline of the Deck. Fully lower the incline of the Deck after each workout.

2. Remove the Safety Key and place it in a secure location.

**!** When this machine is not in operation, remove the Safety Key and keep out of the reach of children.

3. Make sure that the power switch is turned Off, and the power cord is disconnected.

4. You must fold the treadmill before you move it. Never move the treadmill if it is not folded.

**!** Never move the machine with the Walking Deck not folded. Rotating or moving parts can pinch, resulting in personal injury.

5. Make sure that there is safe clearance around, on and above your treadmill. Make sure there is no object to spill or cause blockage from the fully folded position.

**!** Be sure there is adequate height clearance for the raised deck.

6. With your right hand, push and hold down the Walking Deck Release Button. Using the lifting handle found below the rear of the walking belt, lift the walking deck fully upward and engage the hydraulic lift. The Walking Deck Release Button can be released when the walking deck has moved about 10 inches (25.4 cm). Be sure that the hydraulic lift is correctly locked in place. You will hear an audible click when the hydraulic lift shifts into the locked position.

**!** Use proper safety precautions and lifting techniques. Bend your knees and elbows, keep your back straight and pull up equally with both arms. Make sure that your own physical strength is capable of lifting the walking deck until it engages the locking mechanism. Use a second person if necessary.

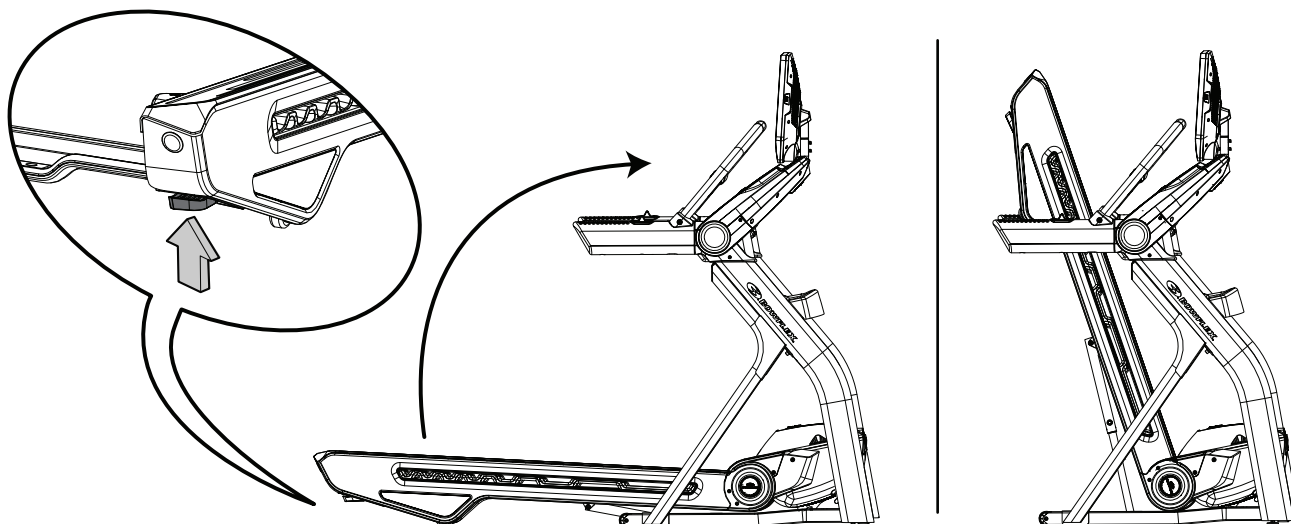

**!** Do not use the walking belt or rear roller to lift the treadmill. These parts do not lock in place and can abruptly move. Injury to you or damage to the machine can occur.

7. Make sure that the locking mechanism is engaged. Carefully pull back on the walking deck and make sure that it does not move. When you do this, keep clear of movement path in case the treadmill lock is not properly engaged.

**!** Do not lean against the treadmill when it is folded. Do not put items on it that could cause it to become unstable or fall.

Do not connect the power cord or try to operate the treadmill in the folded position.

8. Stand to one side of the treadmill. Place your front foot so it pins the Base Assembly. Grasping the Side Handrail, carefully pivot the treadmill rearward until it is balanced fully on the transport wheels. Be sure not to pivot the machine too far. Hold the treadmill in the balanced position.

**!** This step may require two persons, one on each side of the treadmill. The treadmill is heavy and can be awkward. Make sure that your own physical strength is capable of pivoting the machine.

Always wear fully enclosed shoes when moving this machine. Do not move the machine with bare feet or only wearing socks.

Do not use the Console or lifted Walking Deck to pivot or move the treadmill. Injury to you or damage to the machine can occur.

Keep clear of the movement path of the lifted Walking Deck.

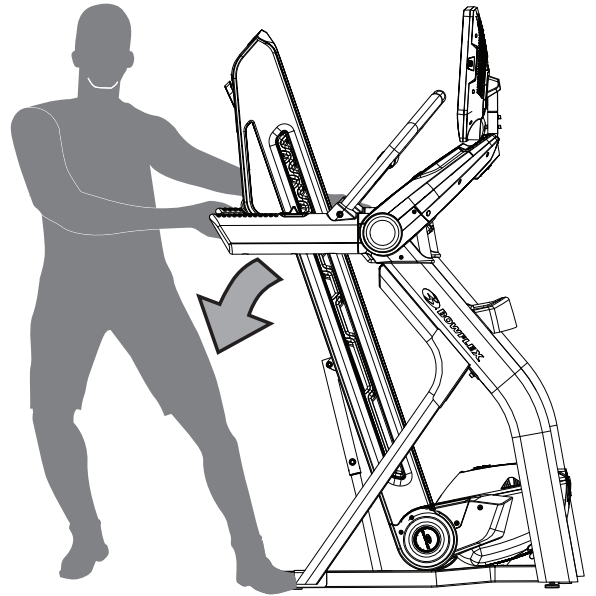

9. Grasping the Side Handrail and the front of the Upright, safely roll the treadmill to the desired location.

**!** The treadmill is heavy and can be awkward. Make sure that your own physical strength is capable of moving the machine.

Place the machine on a clean, hard, level surface, free from unwanted material or other objects that may hamper your ability to move freely. A rubber mat should be used below the machine to prevent the release of static electricity and protect your flooring.

Do not put objects in the path of the walking deck when lowered.

*NOTICE:* Move the machine carefully so that it does not hit other objects. This can damage the Console operation, the treadmill, or the area around the machine.

10. Safely lower the treadmill into the desired position. Be sure there is adequate space for the machine before lowering it.

11. Prior to use, refer to the "Unfolding the Machine" procedure in this manual.

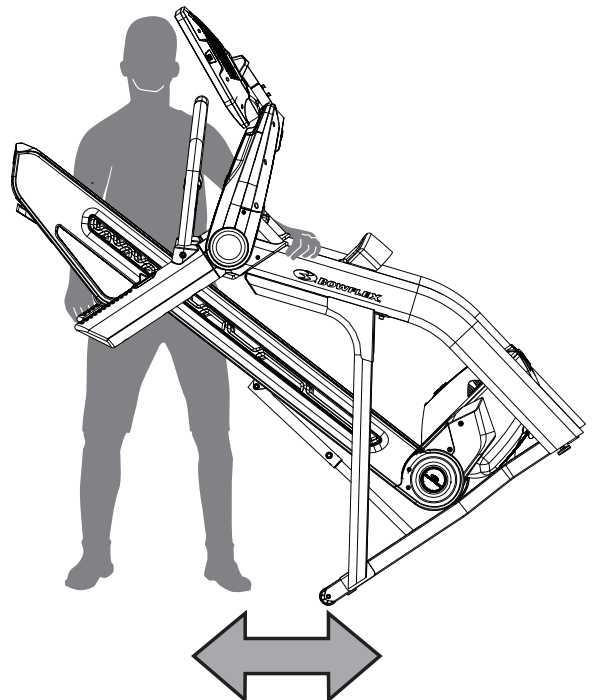



## Unfolding the Machine

1. Make sure there is sufficient space to lower the walking deck.

**!** Keep a minimum clearance behind the machine of 2 m (79") and 0.6 m (24") on each side. This is the recommended safe distance for access, movement and emergency dismounts from the machine.

Place the machine on a clean, hard, level surface, free from unwanted material or other objects that may hamper your ability to move freely with a sufficient clear workout area. A rubber mat below the machine is recommended to prevent electrostatic discharge and protect your floor.

Be sure that the workout space you are utilizing has adequate height clearance, taking into consideration the height of the user and the maximum incline of the deck.

2. Make sure there is no object on or around the treadmill to spill or cause blockage from the fully unfolded position.

3. Slightly push the walking deck toward the console. With your right hand, push and hold down the Walking Deck Release Button and pull the walking deck away from the console. Once the end of the walking deck has moved about 25.4 cm (10 inches), release the button and move to the side of the machine. Continue to pull the walking deck.

**!** Keep clear of the movement path of the walking deck.

4. The hydraulic lift is set up to drop lightly. Hold onto the walking deck until approximately 2/3 of the movement down. Lower the weight with your legs. The walking deck can possibly drop quickly in the last part of the movement.

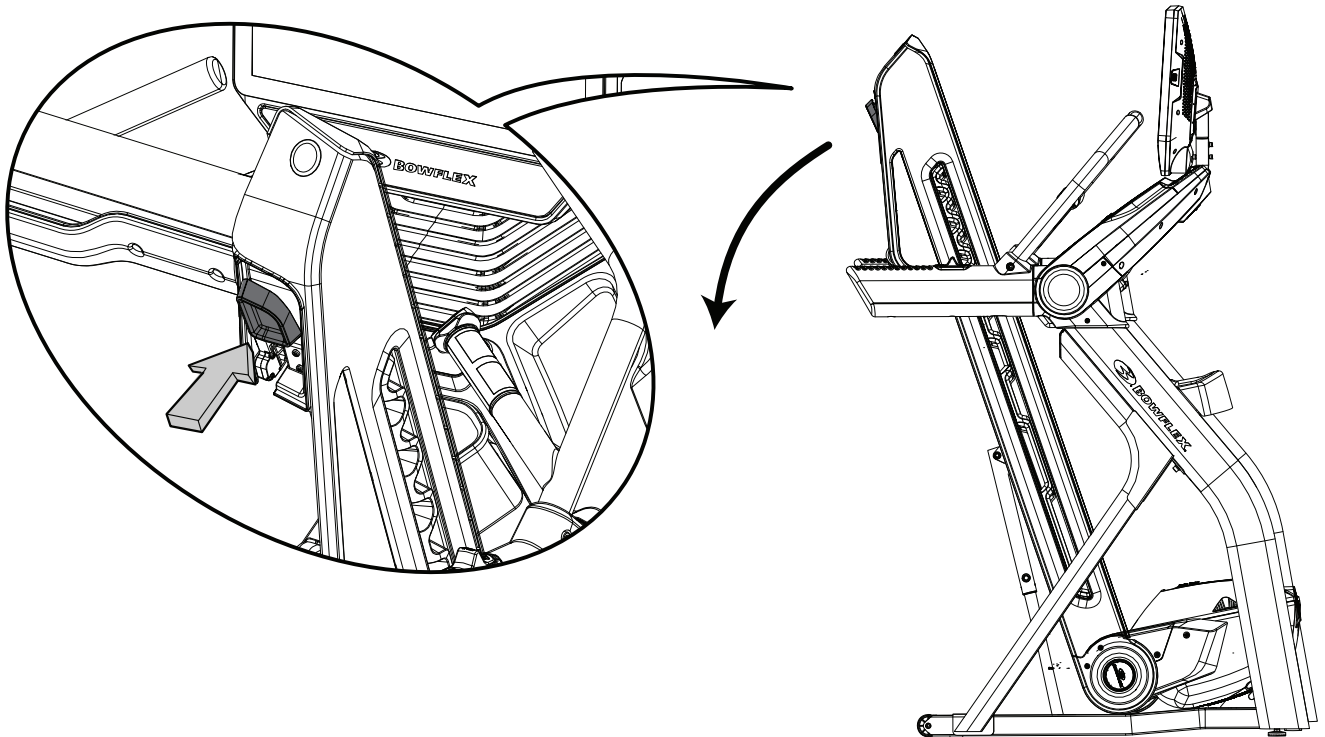

## Leveling the Machine

The machine needs to be leveled if your workout area is uneven. To adjust:

1. Place the machine in your workout area.
2. Adjust the levelers until they all contact the floor.

 **Do not adjust the levelers to such a height that they detach or unscrew from the machine. Injury to you or damage to the machine can occur.**

3. Adjust until the machine is level.

Make sure the machine is level and stable before you exercise.

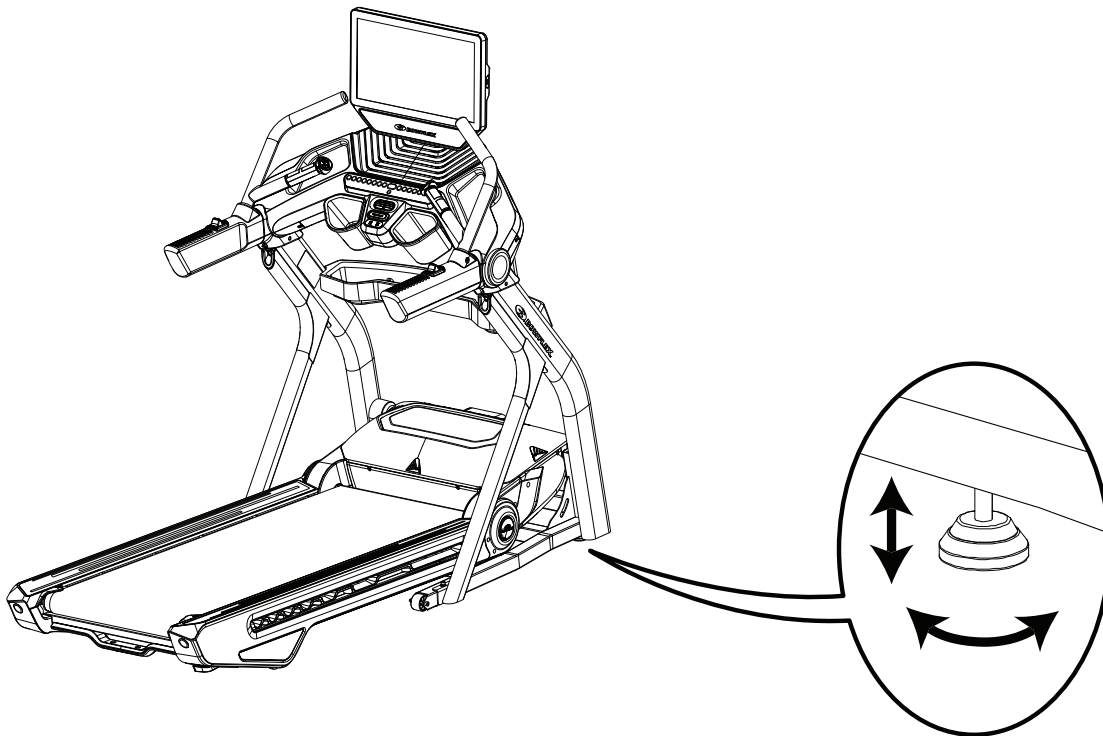

## Treadmill Belt

Your treadmill comes equipped with a durable, high quality walking belt designed to provide many hours of reliable service. The walking belt on a treadmill that has not been operated for a length of time, either in factory packaging or after assembly, can exhibit a “thumping” noise when started. This is due to the belt taking on the curve of the front and rear rollers. This is a common occurrence and does not indicate a problem with your machine. After the treadmill has been used for a short period of time the thumping noise will discontinue. The amount of time will vary depending on the temperature and humidity of the environment where the treadmill is placed.

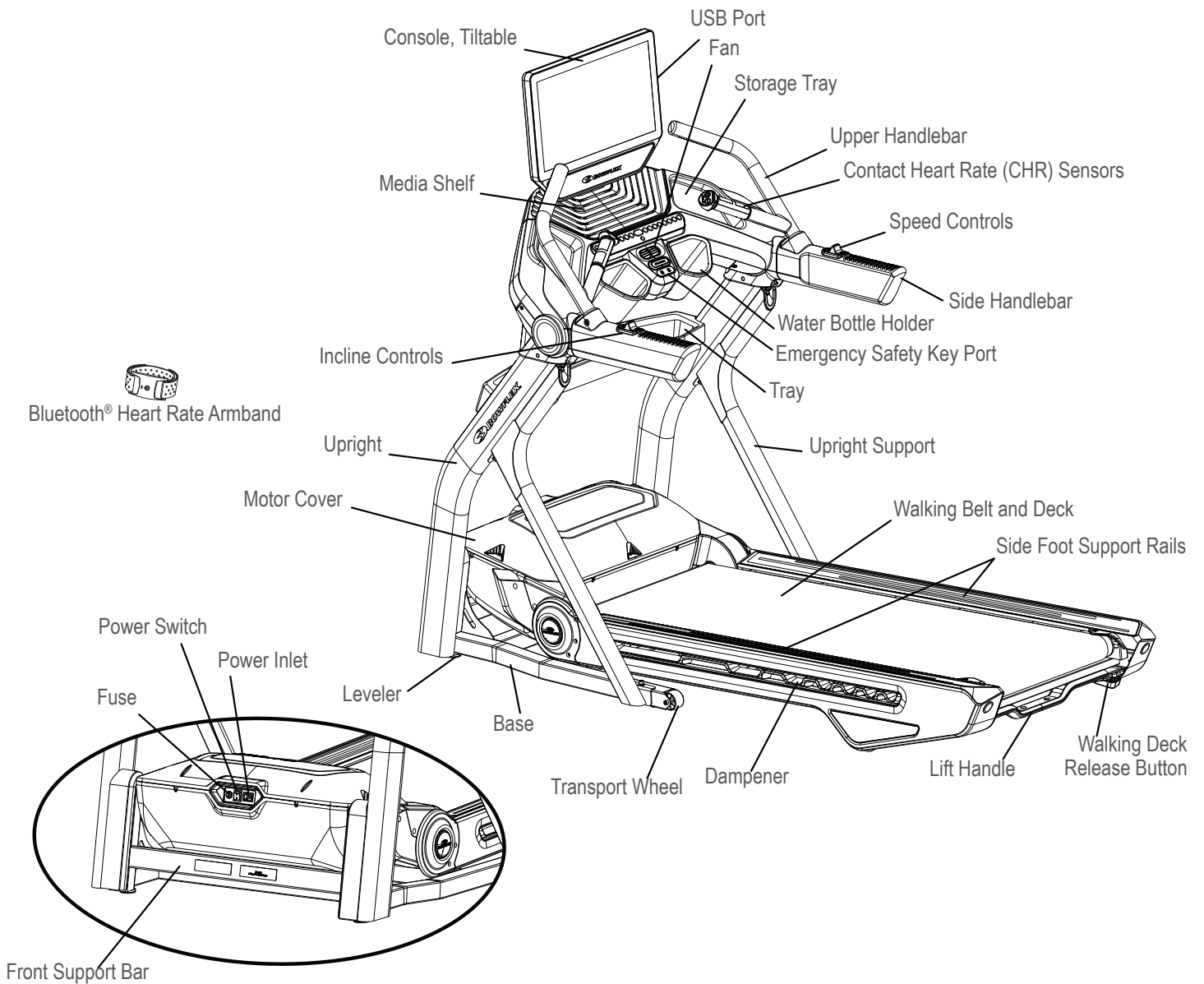

## **⚠ WARNING**

Use the values calculated or measured by the machine's computer for reference purposes only. The heart rate displayed is an approximation and should be used for reference only. Over exercising may result in serious injury or death. If you feel faint stop exercising immediately.

## Console

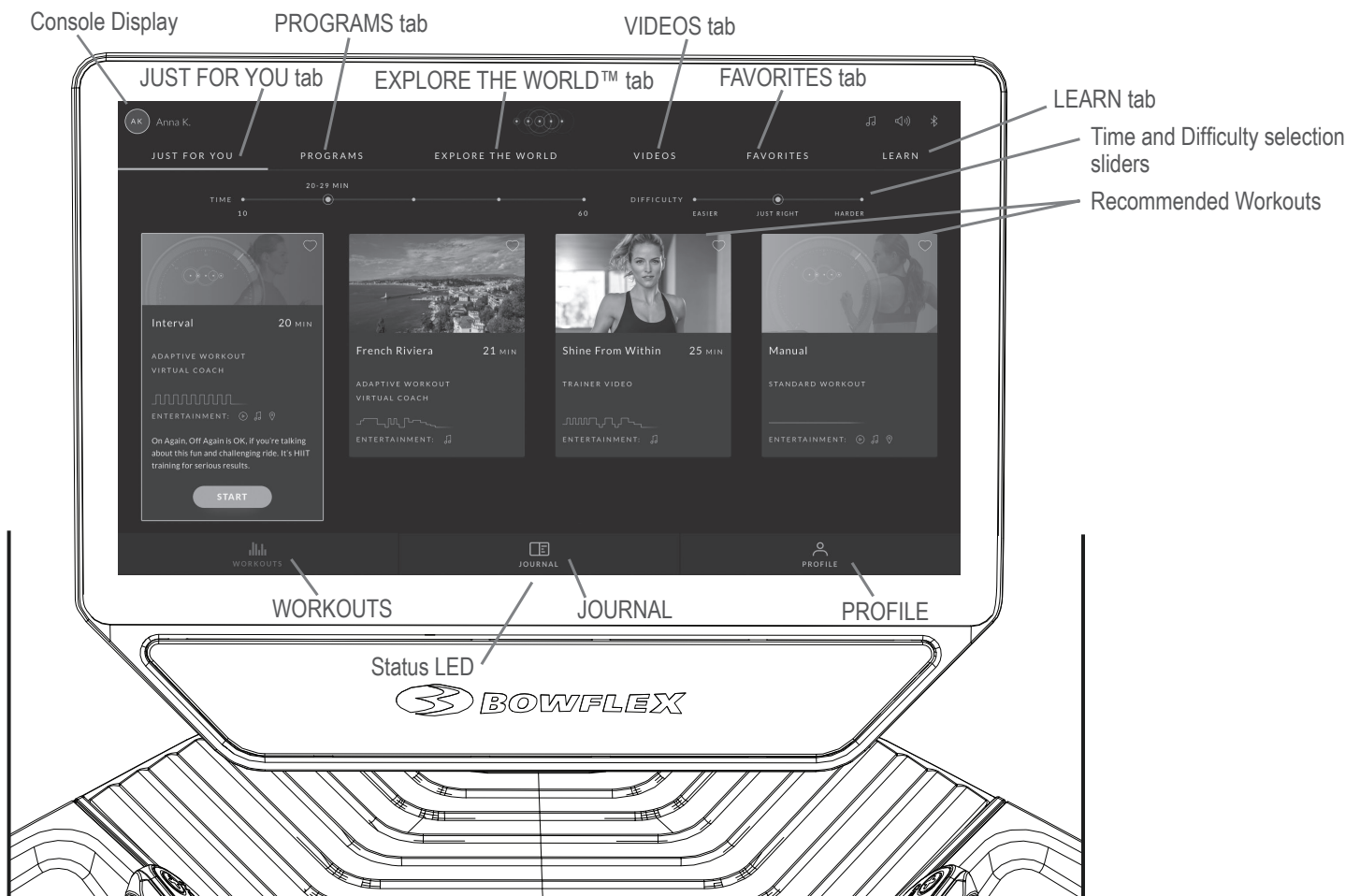

You can access your JRNY™ membership\* through the console of this Bowflex™ machine. With a JRNY™ membership, you receive guided workouts adapted to your capabilities, conveniently displayed on your console, and friendly virtual voice coaching designed to support you on your journey to long-term fitness success.

**Note:** Users without a JRNY™ membership\* may find some content disabled or locked. All coaching, custom workouts, Explore The World™ virtual outdoor immersive runs and trainer lead workout videos are only available through a Wifi connection with a JRNY™ membership. Available workouts can be found on the Programs tab, Explore the World™ tab, Workouts, and the JUST FOR YOU tab.

### Console Display

The Console Display home page includes convenient access to basic features, such as manual and standard workout programs. Everything can be controlled with a simple touch of the Display. Just touch the Display to make a selection, start a workout, or to simply wake up the Console.

**Note:** The buttons on the back of the Console are for factory reset and recovery. They are not intended for customer use. The Power button turns off the backlight on the Console, so it appears off but the electronics are still on.

### JUST FOR YOU tab

After logging in, the Just For You tab is the starting, or home screen for your machine. Guided adaptive workout options\* and educational videos are presented here, encouraging you on your fitness journey. Tap on any of the available options to see additional details and to start the workout.

\* A JRNY™ membership is required for the JRNY™ experience – see [www.bowflex.com/jrny](http://www.bowflex.com/jrny) for details. For United States and Canada customers, you can obtain a JRNY™ membership by calling 800-269-4126 or visiting [www.bowflex.com/jrny](http://www.bowflex.com/jrny). Where available (including the United States), you can also obtain a JRNY™ membership by downloading the JRNY™ app onto your phone or tablet and signing up within the downloaded app. JRNY™ memberships may not be available in all countries.

**Note:** You can use the Time and Difficulty selection sliders to set the Recommended Workout. Users without the JRNY™ membership\* will only see the Time selection slider.

### PROGRAMS tab

The Programs tab provides access to all guided adaptive workouts (with or without virtual voice coaching)\*, along with the standard workouts programs.

**Note:** Only the basic workouts and functions will be available for use without a Wifi connection.

 **Exercise on this machine requires coordination and balance. Be sure to anticipate that changes in belt speed and incline angle of deck can occur during workouts, and be attentive in order to avoid loss of balance and possible injury.**

### EXPLORE THE WORLD™ tab

The Explore The World™ workouts allow you to run through virtual outdoor destinations, with the angle of the walking deck adjusting to the terrain.

**Note:** A Wifi connection with a JRNY™ membership is required to do the Explore The World™ workouts.

 **Exercise on this machine requires coordination and balance. Be sure to anticipate that changes in belt speed and incline angle of deck can occur during workouts, and be attentive in order to avoid loss of balance and possible injury.**

### VIDEOS tab

The Videos tab provides videos led by fitness trainers\*, categorized by difficulty and organized by time.

### FAVORITES tab

Quick access to your favorite content. To add an option to your Favorites tab, tap on the heart icon in the upper-right corner.

### LEARN tab

Provides educational videos and key feature information about fitness.

### Recommended Workouts

Recommended workouts are based on your current fitness level, past workouts and selected time and difficulty settings. Tap on a Suggested Workout card to see an expanded description.

**Note:** Users without a JRNY™ membership\* will see only the Time selection slider.

### WORKOUTS

The Workouts tab centrally collects all of the available workouts and educational videos.

 **Exercise on this machine requires coordination and balance. Be sure to anticipate that changes in belt speed and incline angle of deck can occur during workouts, and be attentive in order to avoid loss of balance and possible injury.**

### JOURNAL

Displays the workout summary (Overview), Past Workouts, and Awards for the selected User Profile.

\* A JRNY™ membership is required for the JRNY™ experience – see [www.bowflex.com/jrny](http://www.bowflex.com/jrny) for details. For United States and Canada customers, you can obtain a JRNY™ membership by calling 800-269-4126 or visiting [www.bowflex.com/jrny](http://www.bowflex.com/jrny). Where available (including the United States), you can also obtain a JRNY™ membership by downloading the JRNY™ app onto your phone or tablet and signing up within the downloaded app. JRNY™ memberships may not be available in all countries.

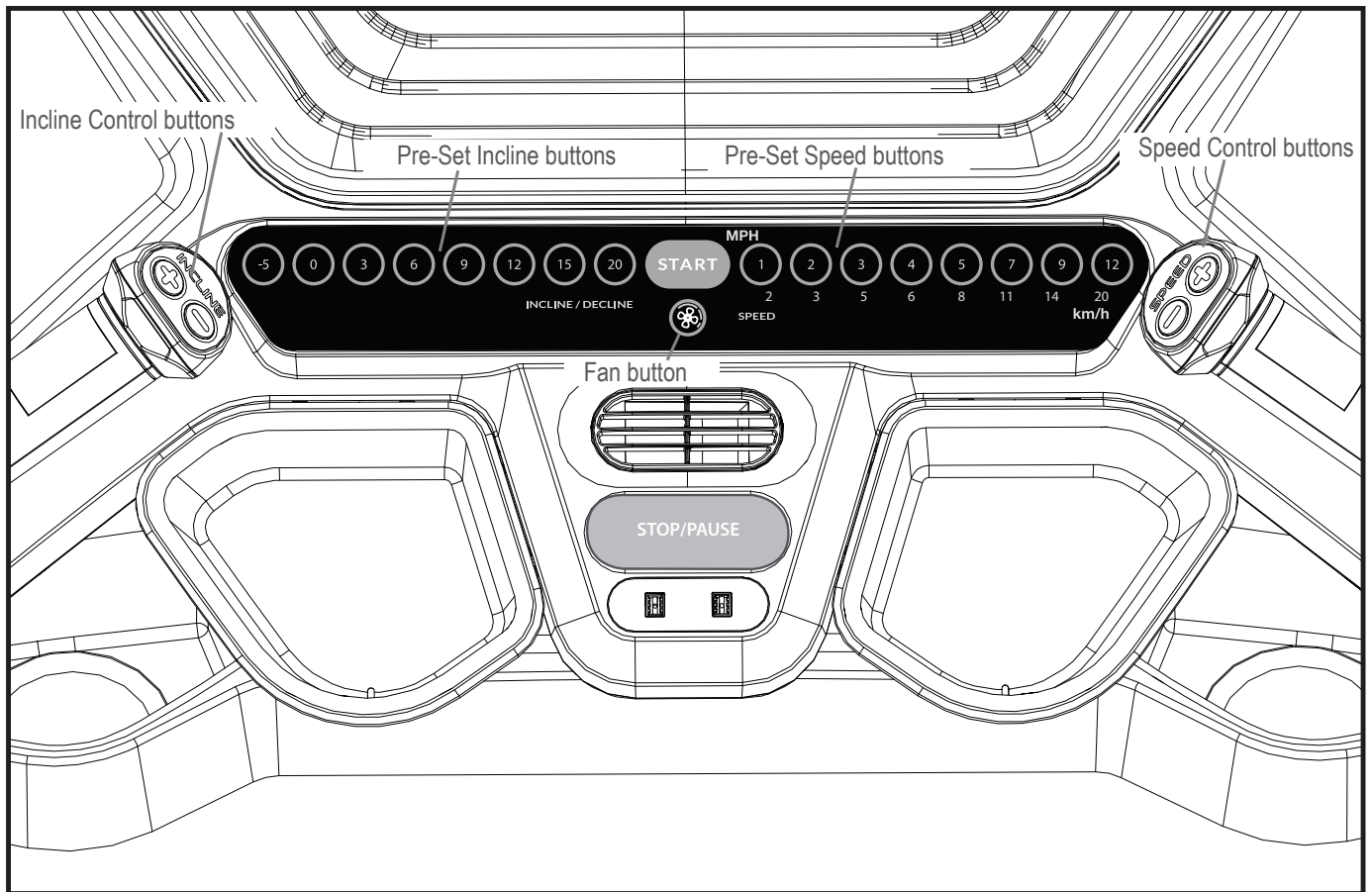

## PROFILE

View and edit your User Profile details, settings, and JRNY™ membership information.

## Status LED

The Status LED shows if the Console is activated and starting up/operating correctly (LED is on), or if the Console is experiencing an error (LED blinks 3 times). To reset the Console during an error, disconnect the power to the machine for 30 seconds and reconnect it.

## Incline Control buttons

The Incline Control buttons are used to Increase (+ and ▲) / Decrease (- and ▼) the Incline value of the Walking Deck.

**Note:** The Incline Control buttons can provide a negative, or declined, level to the Walking Deck.

## Pre-Set Incline buttons

Selects an incline setting for the Walking Deck.

## Speed Control buttons

The Speed Control buttons are used to Increase (+ and ▲) / Decrease (- and ▼) the speed of the Walking Deck.

## Pre-Set Speed buttons

Selects a speed setting for the Walking Belt.

## START button

Push to start the currently selected workout Program, or resume a paused workout.

### Fan button

Controls 4-speed fan (off, low, medium, high).

### STOP/PAUSE button

Push to pause a workout or end a paused workout.

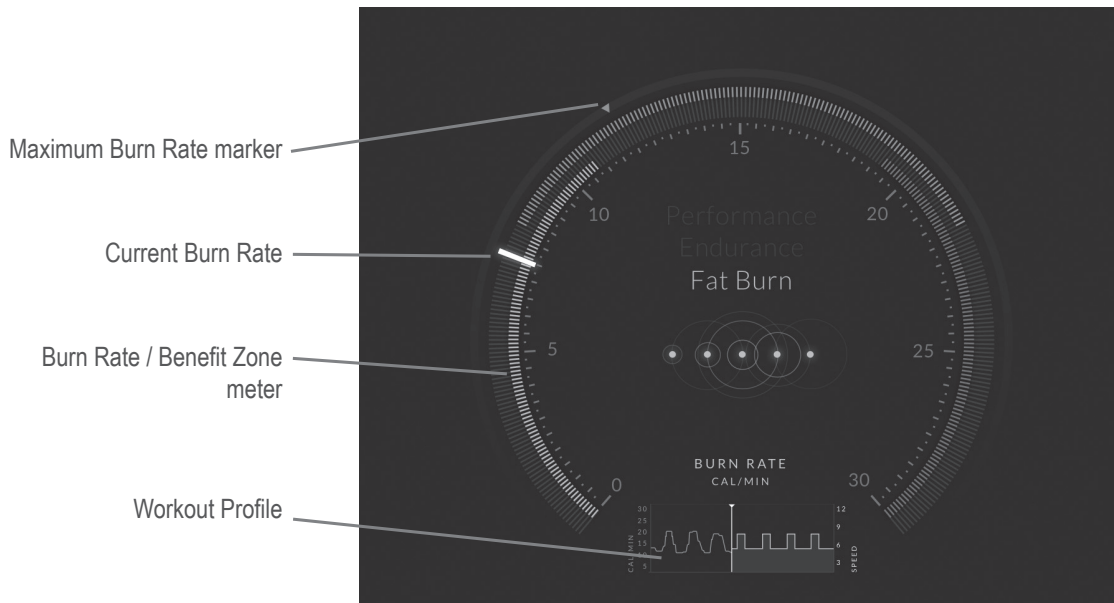

### Burn Rate / Benefit Zone meter

The Burn Rate metric shows the level of calories being burned per minute. This rate is a function of Intensity, which is the current rate of speed and incline level. As either of those values increase, the Burn Rate will increase.

The Benefit Zone meter will be displayed during Standard and Manual workouts, with three suggested zones: Fat Burn, Endurance, and Performance.

### Workout Profile

The Workout Profile is a visualization of the workout (showing intensity). The higher the profile line, the more intense the workout.

### Interval Time

Interval Time shows the remaining time of the current interval.

### Maximum Burn Rate marker

The Maximum Burn Rate marker is an indicator that shows the highest rate of calorie burn achieved during the current workout.

### Burn Rate Target range

The Burn Rate Target range is based on the selected User Profile. A range of Burn Rate segments are activated during an Interval workout. The intensity of the range is based on the Workout Profile display.

**Note:** For a more exact calorie burn rate and suggested target range, be sure to complete a Fitness Assessment workout and keep the User Profile current.

**!** The Target Range is a suggested workout level, and should only be followed if your physical fitness level allows.

During an Interval workout, the Sprint range will be the red segments, and the Recover range will be the blue segments.



## Metrics Bar



### Incline

Incline shows the current percent of Incline of the Walking Deck.

**Note:** The machine can provide a negative, or declined, level to the Walking Deck.

### Time

Counts in minutes and seconds the total time of your workout (e.g. 15:42 minutes).

### Interval

During an Interval workout, this metric shows the current, active Interval and the total number of Intervals for the workout. Each Interval has a Sprint and a Recover workout segment.

### Distance

Distance is displayed in miles or kilometers based on the user setting

### Calories

Calories counts your total workout calories

### Burn Rate

The Burn Rate metric shows the level of calories being burned per minute. This rate is a function of Intensity, which is the current current rate of speed and incline level. As either of those values increase, the Burn Rate will increase.

### Heart Rate

The Heart Rate metric shows your heart beats per minute. The heart icon will flash when acquiring the rate. With a stable reading, the icon will be shown as solid.



**The heart rate displayed is an approximation and should be used for reference only.**

### Speed

Speed shows your current speed in miles (MI) or kilometers (KM) per hour to one decimal (e.g. 3.4 MI).

### Pace (Average)

Average Pace is not shown on the Metrics Bar, but is displayed with the workout results.

## Speed and Incline Level Controls

The Incline and Speed Level Controls are located on the Side Handlebars and on the end of the lower arm of the Upper Handlebars. The incline and speed of the walking belt can be controlled from these controls. The buttons on the left side include an Incline Increase button and an Incline Decrease button. The controls on the right side include a Speed Increase button and a Speed Decrease button.



**Do not push these buttons when grabbing onto any of the Handlebars.**

## Using the Bowflex™ JRNY™ App on your Portable Device (Optional)

Though you can access your completed workout information from your console with your JRNY™ membership, you can also access this information remotely on your own device. Simply download the JRNY™ app to your device for access to your JRNY™ membership.

1. Download the app, named “Bowflex™ JRNY™ App”. The app is available on Google Play™ and the App Store.

**Note:** For a complete list of supported devices, review the app on the App Store or Google Play™.

2. Follow the instructions on the app to sync your device to your Bowflex™ JRNY™ membership.

When your device has access to the account, you will be able to review past workouts, coaching, and upcoming workouts with your JRNY™ membership\*.

## USB Charging

If a USB Device is attached to the USB Port, the Port will attempt to charge the Device. The power supplied from the USB Port may not be enough to operate the Device and charge it at the same time.

## Bluetooth® Heart Rate Monitor Enabled

Your fitness machine is equipped to be able to receive a signal from a Bluetooth® Heart Rate (HR) Monitor. Follow the instructions provided with your Bluetooth® HR monitor.

 **If you have a pacemaker or other implanted electronic device, consult your doctor before using a Bluetooth® strap or other Bluetooth® heart rate monitor.**

**Note:** Be sure to remove the protective cover (if provided) from the Heart Rate Sensor before use.

## Bluetooth® Heart Rate Armband

A Bluetooth® Heart Rate Armband is provided with your fitness machine. To use the Bluetooth® Heart Rate Armband, follow the instructions that were included with the Armband.

 **If you have a pacemaker or other implanted electronic device, consult your doctor before using a Bluetooth® armband or other Bluetooth® heart rate monitor.**

**Note:** Be sure to remove the protective cover (if provided) from the Heart Rate Sensor before use.

1. Put the Bluetooth® Heart Rate Armband onto the upper portion of your forearm.
2. Confirm that the Bluetooth® wireless connection is active on the machine. If the Bluetooth® icon is blue, then it is active. If the icon is red, then the Bluetooth® wireless connection must be activated. To activate the Bluetooth® wireless connection:
  - a. Tap the Bluetooth® icon.
  - b. Tap “Manage Bluetooth®”.
  - c. Slide the option from “OFF” to “ON”.
  - d. Tap Back to exit.
3. When ready to exercise, start your workout.
4. Push the On/Off LED button on the Heart Rate Armband. Be sure to only push the On/Off LED button once.

\* A JRNY™ membership is required for the JRNY™ experience – see [www.bowflex.com/jrny](http://www.bowflex.com/jrny) for details. For United States and Canada customers, you can obtain a JRNY™ membership by calling 800-269-4126 or visiting [www.bowflex.com/jrny](http://www.bowflex.com/jrny). Where available (including the United States), you can also obtain a JRNY™ membership by downloading the JRNY™ app onto your phone or tablet and signing up within the downloaded app. JRNY™ memberships may not be available in all countries.

5. During your workout, the Heart Rate Armband may take up to 60 seconds to connect. When connected, the Bluetooth® Heart Rate Device icon will be displayed along with your heart rate.

**Note:** The Armband can only be connected once to an active workout. If the On/Off LED button is pushed after being connected, the workout must be restarted.



## Bluetooth® Audio (in or out)

Your machine is able to play audio across a Bluetooth® connection from your smart device through the treadmill speakers. The machine can also stream audio from the console to your Bluetooth® device (such as Bluetooth® headphones).

**Note:** Bluetooth® audio can only be streamed in one direction (in or out) at a time.

## Contact Heart Rate Sensors

Contact Heart Rate (CHR) sensors send your heart rate signals to the Console. The CHR sensors are the stainless steel parts of the Handlebars. To use, put your hands comfortably around the sensors. Be sure that your hands touch both the top and the bottom of the sensors. Hold firm, but not too tight or loose. Both hands must make contact with the sensors for the Console to detect a pulse. After the Console detects four stable pulse signals, your initial pulse rate will be shown.

Once the Console has your initial heart rate, do not move or shift your hands for 10 to 15 seconds. The Console will now validate the heart rate. Many factors influence the ability of the sensors to detect your heart rate signal:

- Movement of the upper body muscles (including arms) produces an electrical signal (muscle artifact) that can interfere with pulse detection. Slight hand movement while in contact with the sensors can also produce interference.
- Calluses and hand lotion may act as an insulating layer to reduce the signal strength.
- Some Electrocardiogram (EKG) signals generated by individuals are not strong enough to be detected by the sensors.
- The proximity of other electronic machines can generate interference.

If your heart rate signal ever seems erratic after validation, wipe off your hands and the sensors and try again.



**The heart rate displayed is an approximation and should be used for reference only.**

## Heart Rate Calculations

Your maximum heart rate usually decreases from 220 Beats Per Minute (BPM) in childhood to approximately 160 BPM by age 60. This fall in heart rate is usually linear, decreasing by approximately one BPM for each year. There is no indication that training influences the decrease in maximum heart rate. Individuals of the same age could have different maximum heart rates. It is more accurate to find this value by getting a stress test than by using an age related formula.

Your at rest heart rate is influenced by endurance training. The typical adult has an at rest heart rate of approximately 72 BPM, where as highly trained runners may have readings of 40 BPM or lower.

The Heart Rate table is an estimate of what Heart Rate Zone (HRZ) is effective to burn fat and improve your cardiovascular system. Physical conditions vary, therefore your individual HRZ could be several beats higher or lower than what is shown.

The most efficient procedure to burn fat during exercise is to start at a slow pace and gradually increase your intensity until your heart rate reaches between 60 – 85% of your maximum heart rate. Continue at that pace, keeping your heart rate in that target zone for over 20 minutes. The longer you maintain your target heart rate, the more fat your body will burn.

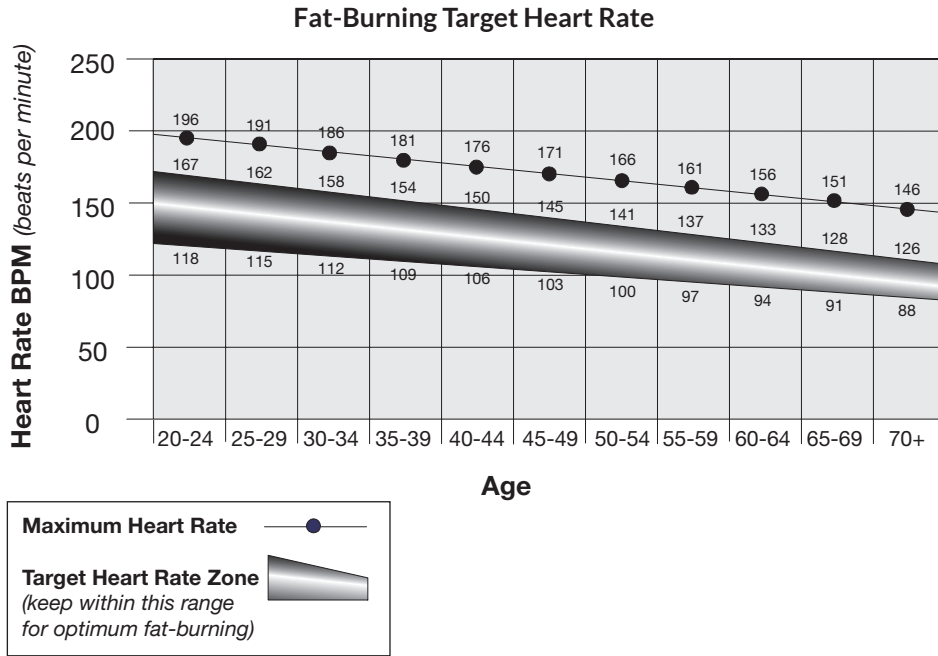

The graph is a brief guideline, describing the generally suggested target heart rates based on age. As noted above, your optimal target rate may be higher or lower. Consult your physician for your individual target heart rate zone.

**Note:** As with all exercises and fitness regimens, always use your best judgment when you increase your exercise time or intensity.

## Fitness Basics

### Frequency

To maintain good health, lose weight and improve your cardiovascular endurance, try and use the Bowflex™ fitness machine a minimum of 3 times per week, 30 minutes each day.

If you are new to exercise (or returning to a regular exercise program), and you are unable to comfortably complete 30 minutes of continuous exercise at one time, just do 5 – 10 minutes, and gradually increase your workout time until you can reach 30 minutes total.

If your schedule is busy, and you are unable to fit 30 minutes of continuous exercise into your day, try accumulating 30 minutes by doing multiple shorter workouts on the same day. For example, 15 minutes in the morning and 15 minutes in the evening.

For best results, combine your Bowflex™ fitness machine workouts with a strength training program using a Bowflex™ home gym or Bowflex™ SelectTech™ dumbbells, and follow the Bowflex™ Body Weight Loss Guide that is included in this manual.

### Consistency

Busy work schedules, family obligations and daily chores can make it difficult to fit regular exercise into your life. Try these tips to increase your chances of success:

Schedule your workouts the same way you schedule meetings or appointments. Select specific days and times each week, and try not to change your workout times.

Make a commitment to a family member, friend or spouse, and encourage each other to stay on track each week. Leave messages with friendly reminders to be consistent, and keep each other accountable.

Make your workouts more interesting by alternating between steady state (single-speed) workouts and interval training (varied speed) workouts. The Bowflex™ fitness machine is even more fun when you add this kind of variety.

### Apparel

It is important to wear appropriate, safe and comfortable footwear and clothing when using the Bowflex™ fitness machine, including:

- Rubber-soled athletic walking or running shoes.
- Exercise clothing that allows you to move freely, and keep comfortably cool.
- Athletic support that provides stability and comfort.



**Do not wear loose clothing or jewelry. This machine contains moving parts. Do not put fingers, feet, or other objects into moving parts of the exercise equipment.**

**Always wear rubber soled athletic shoes when you use this machine. Do not use the machine with bare feet or only wearing socks.**

### Warm-Up\*

Before you use your Bowflex™ fitness machine, consider doing these dynamic warm-up stretches, which will help prepare your body for the workout:

\* Source: Blahnik, Jay. *Full-Body Flexibility, 2nd Edition*. Champaign, IL: Human Kinetics, 2010. HumanKinetics.com

---

### Dynamic Knee Hug

Stand with the feet together. Bring one knee forward and up toward the chest. Place the hands around the shin and pull the knee into the chest. Release the stretch by putting the foot on the floor. Each repetition of the sequence should take 1 to 3 seconds. Repeat as a continuous, controlled, fluid sequence 10 or 20 times. Repeat the stretch with the other leg.

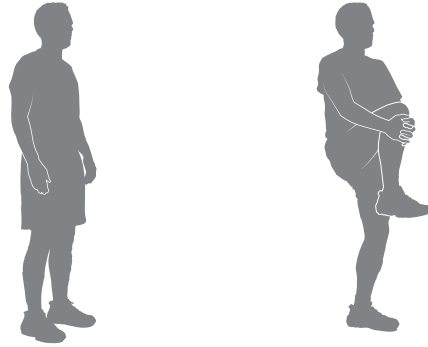

---

### Dynamic Knee Bend

Stand with the feet together. Raise the heel of one foot toward the gluteals. Release the stretch by putting the foot on the floor. Each repetition of the sequence should take 1 to 3 seconds. Repeat as a continuous, controlled, fluid sequence 10 or 20 times. Repeat the stretch with the other leg.

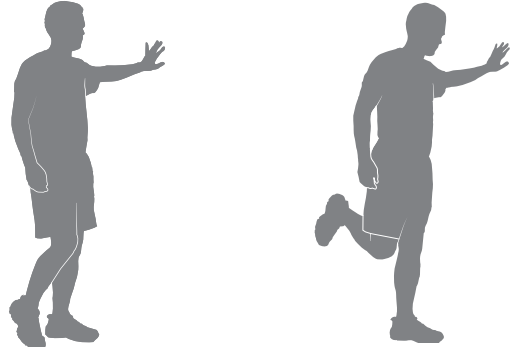

---

### Dynamic Knee Kick

Stand tall and hold one leg up with the hands at hip height, keeping the knee bent. Hold onto a wall for balance with one hand, if necessary. Straighten the knee as far as comfortably possible. Release the stretch by bending the knee. Each repetition of the sequence should take 1 to 3 seconds. Repeat as a continuous, controlled, fluid sequence 10 or 20 times. Repeat the stretch with the other leg.

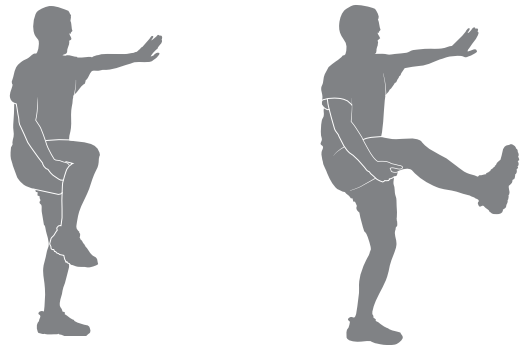

---

### Dynamic Twist

Stand with the feet shoulder-width apart. Bend the elbows; hold the arms out to the sides. Twist the upper body to one side and then the other side as far as comfortably possible. Each repetition of the sequence should take 1 to 3 seconds. Repeat as a continuous, controlled, fluid sequence 10 or 20 times.

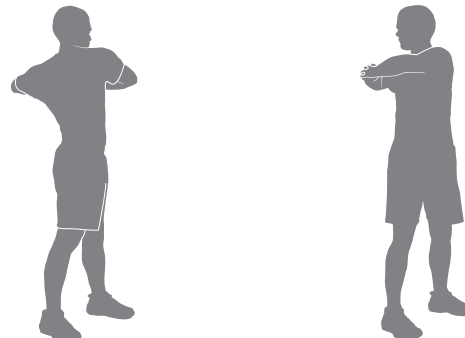

---

### Dynamic Bent Knee Heel Press

Stand with one foot forward and one foot back, hip-width apart and feet facing forward. Bend both knees putting weight on the back heel. Release the stretch by returning to the start position. Each repetition of the sequence should take 1 to 3 seconds. Repeat as a continuous, controlled, fluid sequence 10 or 20 times. Repeat the stretch with the other leg. Touch a wall or hold onto something for balance, if necessary.

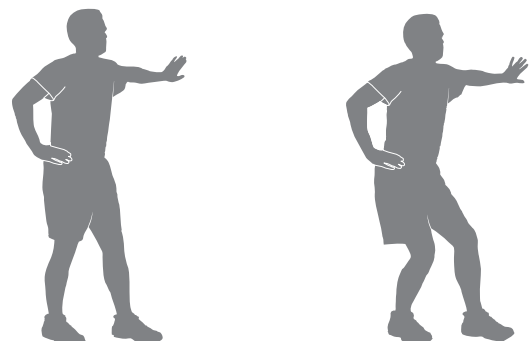

---

### Dynamic Side Reach

Stand with the feet apart, the knees slightly bent and the arms at the sides of the body. Reach with one hand above the head and lean over to the opposite side. Release the stretch by returning to the start position. Then reach with the other hand to the opposite side. Use the other arm to support the body weight on the thigh, if necessary. Each repetition of the sequence should take 1 to 3 seconds. Repeat as a continuous, controlled, fluid sequence 10 or 20 times.

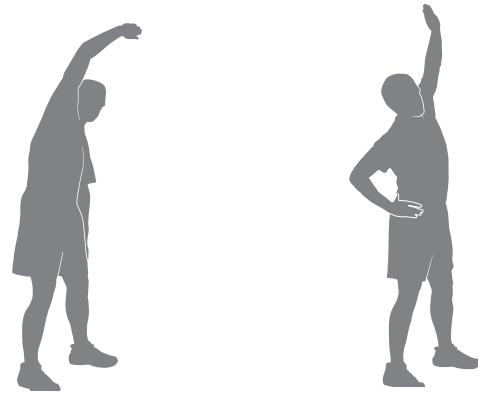

---

## Workouts

Follow these guidelines to ease yourself into a weekly exercise regimen. Use your judgment and/or the advice of your physician or health care professional to find the intensity and level of your workouts.

**⚠ Consult a physician before you start an exercise program. Stop exercising if you feel pain or tightness in your chest, become short of breath, or feel faint. Contact your doctor before you use the machine again. Use the values calculated or measured by the machine's computer for reference purposes only.**

Steady State and Interval Training are 2 types of workouts you can do on your Bowflex™ fitness machine:

### Steady State workouts

A Steady State workout involves slowly increasing your workout speed to a challenging, but comfortable speed you can hold for most of your workout. For example, holding a 3.0 MPH walking pace for the entire workout, except during the warm-up and cool-down. Steady State workouts help you build exercise confidence, stamina and endurance, and are essential to a well-rounded cardiovascular training program.

### Interval Training workouts

An Interval Training workout involves adjusting your speed faster and slower for specific lengths of time to raise and lower your breathing rate, heart rate and calorie burn. Here is a sample Interval Training workout:

- 7 minutes walking at a slow, easy, comfortable speed.
- 1 minute walking at a more challenging speed that is approximately 50% faster.
- 7 minutes walking at a slow, easy, comfortable speed.
- 1 minute walking at a more challenging speed that is approximately 2x faster.
- 7 minutes walking at a slow, easy, comfortable speed.
- 1 minute walking at a more challenging speed that is approximately 50% faster.
- 6 minutes walking at a slow, easy, comfortable speed.

Interval training workouts provide variety and can help you to improve fitness.

The Bowflex™ fitness machine is designed to cushion your joints and muscles, and both Steady State and Interval Training workouts should feel more comfortable than walking or running outside on a hard surface.



## Workout Schedule

Here is a beginner, intermediate and advanced sample workout schedule. Use the workout schedule that reflects your current fitness level. With each of these sample workout schedules, do not move on to the next week until the current week feels easier and comfortable.

<b>Beginner</b>	<b>Week 1</b>	<b>Week 2</b>	<b>Week 3</b>	<b>Week 4</b>	<b>Week 5</b>
<b>Workout 1</b>	Steady State	Steady State	Steady State	Interval Training	Interval Training
<b>Workout 2</b>	Steady State	Steady State	Interval Training	Steady State	Steady State
<b>Workout 3</b>	Steady State	Steady State	Steady State	Interval Training	Interval Training

<b>Intermediate</b>	<b>Week 1</b>	<b>Week 2</b>	<b>Week 3</b>	<b>Week 4</b>	<b>Week 5</b>
<b>Workout 1</b>	Steady State	Steady State	Interval Training	Steady State	Interval Training
<b>Workout 2</b>	Steady State	Interval Training	Steady State	Interval Training	Steady State
<b>Workout 3</b>	Steady State	Steady State	Interval Training	Steady State	Interval Training

<b>Advanced</b>	<b>Week 1</b>	<b>Week 2</b>	<b>Week 3</b>	<b>Week 4</b>	<b>Week 5</b>
<b>Workout 1</b>	Steady State	Interval Training	Interval Training	Interval Training	Interval Training
<b>Workout 2</b>	Interval Training	Steady State	Steady State	Steady State	Interval Training
<b>Workout 3</b>	Steady State	Interval Training	Interval Training	Interval Training	Interval Training



## Cool-Down \*

When you are done using your Bowflex™ fitness machine, consider doing these relaxing stretches, which will help your body recover from the workout and make you more flexible:

---

### Lying Leg Raise

Lie on the floor face up with the legs slightly bent. Lift one leg up toward the ceiling, keeping the knee straight. Place the hands (or a strap) around the thigh and move the leg closer to the head. Hold the stretch for 10 to 30 seconds. Repeat the stretch on the other leg. Keep the head on the floor and do not round the spine.

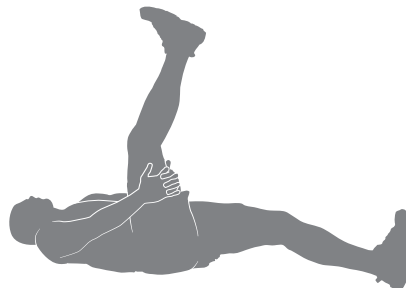

### Side Lying Knee Bend

Lie on the floor on one side of the body and rest the head on the lower arm. Bend the top knee and hold the ankle with the same-side hand, then pull the heel toward the gluteals. Hold the stretch for 10 to 30 seconds. Lie on the other side and repeat the stretch with the other leg. Remember to hold the knees close together.

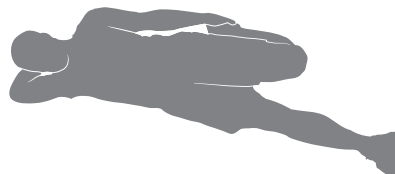

### Lying Figure Four

Lie on the floor face up with the legs bent. Place one foot across the thigh of the opposite leg in the figure four position. Reach for the leg on the floor and pull it toward the chest. Hold the stretch for 10 to 30 seconds. Repeat the stretch with the other leg. Keep the head on the floor.

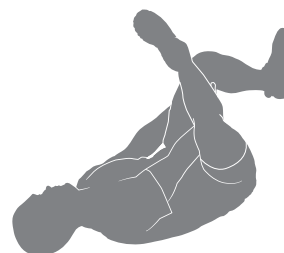

### Seated Twist

Sit on the floor and extend the legs straight out in front of the body with the knees slightly bent. Place one hand on the floor behind the body and the other hand across the thigh. Twist the upper body as far as comfortably possible to one side. Hold the stretch for 10 to 30 seconds. Repeat the stretch on the other side.



### Seated Figure Four

Sit on the floor and extend one leg straight out in front of the body. Place the foot of the other leg across the thigh in the figure four position. Move the chest toward the legs, pivoting at the hip. Hold the stretch for 10 to 30 seconds. Repeat on the other leg. Use the arms to support the back.



\* Source: Blahnik, Jay. *Full-Body Flexibility, 2nd Edition*. Champaign, IL: Human Kinetics, 2010. [HumanKinetics.com](http://HumanKinetics.com)

---

### **Dynamic Heel Drop**

Place the ball of one foot on the edge of a step or staircase. Place the other foot slightly in front. Lower the heel of the back foot as far as comfortably possible, keeping the knee straight. Release the stretch by lifting the heel as high as comfortably possible. Each repetition of the sequence should take 1 to 3 seconds. Repeat as a continuous, controlled, fluid sequence 10 or 20 times. Repeat the stretch with the other leg

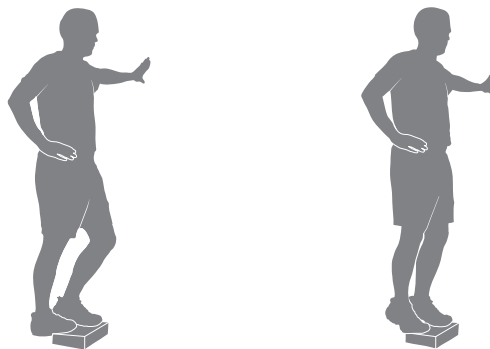

## Initial Console Set-Up

1. With the machine plugged into a functioning wall outlet, the machine will start up and the red Status LED will activate.  
**Note:** The Console may go to sleep if it does not receive any input. Touch the screen of the Console to wake up the machine.
2. The machine will activate and display the Welcome - Connect Wifi screen. Tap on Connect.  
**Note:** A Wifi connection is required to use your Bowflex™ machine. If you do not have a Wifi connection available, contact your Bowflex™ Representative or your local distributor immediately for further assistance.
3. The Console will display the list of available Wifi connections. Tap on the desired Wifi connection, and enter the password. Tap on Connect.
4. The Console will test and connect to the Wifi connection.  
If the Console displays an Update Available screen, tap on the Agree button. The Console will update the software.
5. With a Wifi connection established, tap on Back.
6. Tap on Get Started.
7. The Console will display the options screen. Choose Log In or Create Account. Follow the prompts to register your new fitness machine. When registration is completed, your fitness machine is now ready for use.  
**Note:** The Bowflex™ machine must be registered using a Wifi connection. Once the initial registration and configuration is completed, the machine can be operated without a Wifi connection. However, only the basic workouts and functions will be available for use. All coaching, custom workouts, Explore The World™ virtual outdoor immersive runs and trainer lead workout videos are only available through a Wifi connection with a JRNY™ membership\*.
8. The Console will display the Just for You screen. The screen will prompt you to do your Fitness Assessment workout to get a custom workout\*. You can go to the Learn tab for more information about your options.

## Getting Started

 **Consult a physician before you start an exercise program. Stop exercising if you feel pain or tightness in your chest, become short of breath, or feel faint. Contact your doctor before you use the machine again. Use the values calculated or measured by the machine's computer for reference purposes only.**

**Place the machine on a clean, hard, level surface, free from unwanted material or other objects that may hamper your ability to move freely with a sufficient clear workout area. A rubber mat below the machine is recommended to prevent electrostatic discharge and protect your floor.**

**Be sure that the workout space you are utilizing has adequate height clearance, taking into consideration the height of the user and the maximum incline of the deck.**

1. With the fitness machine in your workout area, inspect the walking belt to make sure it is centered and aligned. If necessary, refer to the "Aligning the Walking Belt" Procedure in the Maintenance section of this manual.
2. Examine below the walking belt for any objects. Be sure it is clear below the machine.
3. Connect the Power Cord to a correctly grounded / earthed AC wall outlet.

 **Do not step on the power cord and plug.**

**Note:** The machine is designed to plug directly into a properly wired and grounded / earthed outlet.

4. If you use a Bluetooth® Heart Rate Monitor, follow the instructions to properly operate it.
5. Switch on the power. Power is now supplied to the machine.

\* A JRNY™ membership is required for the JRNY™ experience – see [www.bowflex.com/jrny](http://www.bowflex.com/jrny) for details. For United States and Canada customers, you can obtain a JRNY™ membership by calling 800-269-4126 or visiting [www.bowflex.com/jrny](http://www.bowflex.com/jrny). Where available (including the United States), you can also obtain a JRNY™ membership by downloading the JRNY™ app onto your phone or tablet and signing up within the downloaded app. JRNY™ memberships may not be available in all countries.

6. Straddle the walking belt and stand on the Side Foot Support Platforms. Put the Safety Key into the Safety Key Port and clip the Safety Key cord to your clothing.



**Care should be used when mounting or dismounting the machine.**

**To prevent injury, stand on the Side Foot Support Platforms before you start the machine or end a workout. Do not dismount the machine by standing on the moving Walking Belt and exiting off the rear of the machine.**

- Examine the Safety Key and be sure it is connected to the Console correctly.

**Note:** If the Safety Key is not installed, the machine will allow the User to perform all activities except to activate the Walking Belt. The Console will display reminders to insert the Safety Key ( " Safety Key Disconnected. To do a workout, insert the Safety key. " ).

- Always attach the Safety Key Clip to your clothing during workouts.

- If there is a need to immediately stop the machine, pull out the Safety Key to shut off the power to the Belt and Incline Motors. This will quickly stop the belt (brace yourself- this is an abrupt stop) and clear the workout. Push the PAUSE/STOP button to stop the belt and pause the program.

7. Log into the machine or select Guest User. The adaptive workouts\* cannot be recommended unless you are logged in to the machine.

**Note:** Be aware that the Walking Deck is shipped with the Walking Deck in a negative, or declined, Incline setting. For the Walking Deck to be level, adjust the Incline setting to "0".

8. With your desired workout selected, push the START button.
9. The Entertainment Options screen for this workout is displayed. Select from the provided entertainment options.
10. The Walking Belt will start moving and will shortly be up to speed. Be sure to carefully step onto the walking belt.



**Always use the handlebars to step on or off the treadmill, or when the incline or speed change.**

**To perform an emergency dismount, grab onto the Front or Side Handlebars and safely step onto the Side Foot Platforms. Bring the Walking Belt to a stop and carefully step off the machine.**

**Note:** Your treadmill comes equipped with a durable, high quality walking belt designed to provide many hours of reliable service. The walking belt on a treadmill that has not been operated for a length of time, either in factory packaging or after assembly, can exhibit a "thumping" noise when started. This is due to the belt taking on the curve of the front and rear rollers. This is a common occurrence and does not indicate a problem with your machine. After the treadmill has been used for a short period of time the thumping noise will discontinue. The amount of time will vary depending on the temperature and humidity of the environment where the treadmill is placed.

## Power Up Mode / Just For You Tab

The Console will enter Power-Up mode / Just For You tab when plugged into a power source and the On/Off switch is turned on.

## Changing Incline Levels

Push the Incline Level Increase or Decrease buttons to change the incline angle of the Deck at any time with the Safety Key installed. To rapidly change the Incline level push the desired Pre-Set Incline button. The Deck will adjust to the selected incline setting.



**Be sure the area below the machine is clear before lowering the Deck. Fully lower the Deck after each workout.**

**Exercise on this machine requires coordination and balance. Be sure to anticipate that changes in belt speed and incline angle of deck can occur during workouts, and be attentive in order to avoid loss of balance and possible injury.**

**Be sure that the workout space you are utilizing has adequate height clearance, taking into consideration the height of the user and the maximum height of the fully inclined Deck.**

**Note:** When the Deck is at a 20% incline, the maximum belt speed is 13 kph (8 mph).



## Changing the Walking Belt Speed

During a workout, the Walking Belt can be adjusted by 0.1 mph/kph increments. To adjust the speed of the Walking Belt, push the Speed Increase or Decrease buttons on the right Upper or Side Handlebars.

To rapidly change the Speed level, push the desired Pre-Set Speed button. The Walking Belt will adjust to the desired speed.

## Pausing or Stopping a Workout

1. With a firm hold on the Handlebars, step off of the belts and onto the Side Foot Support Platforms on either side of the Walking Deck.
2. Push PAUSE/STOP to pause the workout. The belts will slow to a complete stop.

**Note:** If a paused workout is not restarted in 5 minutes, the machine will end the workout and display the workout results.

3. To restart your workout, push the START button. To end your workout, push PAUSE/STOP again.
4. After the workout, the Console will display your workout results.
5. Tap Continue.
6. The Console will go to the overview of the Latest Workout of the Journal tab.

## Power Off and Restart the Machine

**Note:** When active, the Bowflex™ machine checks for software updates and installs them. If the machine is de-activated for a period of time, it may try to install updates when restarted.

1. To power off the machine, log the user out from the Console.
2. Flip the power switch to off.
3. Unplug the power cord from the machine.



**To prevent unsupervised operation of the machine always turn the power switch to Off, remove the Safety Key, and disconnect the power cord from the wall outlet and machine power input. Place the power cord in a secure location.**

To restart the machine:

1. Let the machine sit without power for at least a minute.
2. Re-attach the power cord to the machine.
3. Flip the power switch to on. The machine will start up.

# Maintenance

Read all maintenance instructions fully before you start any repair work. In some conditions, an assistant is required to do the necessary tasks.

 **Equipment must be regularly examined for damage and repairs. The owner is responsible to make sure that regular maintenance is done. Worn or damaged components must be repaired or replaced immediately. Only manufacturer supplied components can be used to maintain and repair the equipment.**

**If at any time the Warning labels become loose, unreadable or dislodged, replace the labels. If purchased in US/Canada, contact Customer Service for replacement labels. If purchased outside US/Canada, contact your local distributor for them.**

## DANGER

**To reduce the risk of electrical shock or unsupervised usage of the equipment, always unplug the power cord from the wall outlet and the machine and wait 5 minutes before cleaning, maintaining or repairing the machine. Place the power cord in a secure location.**

**Daily:** Before each use, examine the exercise machine for loose, broken, damaged, or worn parts. Do not use if found in this condition. Repair or replace all parts at the first sign of wear or damage, except for the Walking Deck. The Walking Deck is designed for wear on both sides of it. If only one side of the Walking Deck is worn, a replacement Deck is not required. It is recommended that a qualified service technician is used to flip the Walking Deck. After each workout, use a damp cloth to wipe your machine and Console free of moisture.

**Note:** Avoid excessive moisture on the Console.

**Weekly:** Check that the front and rear rollers operate smoothly. Wipe the machine to remove dust, dirt, or grime.

 **Do not remove the Motor Cover, as dangerous voltages and moving parts are present. The components are serviceable only by approved service personnel or by following service procedures supplied by Nautilus, Inc.**

**Note:** Do not use petroleum based products.

**Monthly or after 20 hours:** Make sure all bolts and screws are tight. Tighten as necessary.

**Quarterly:** Or after 25 hours—Lubricate the walking belt with a 100% pure silicone lubricant.

 **Silicone lubricant is not intended for human consumption. Keep out of reach of children. Store in a safe place.**

**Note:** Do not use petroleum based products.

## Cleaning

### DANGER

**To reduce the risk of electrical shock, always unplug the power cord and wait 5 minutes before cleaning, maintaining or repairing this machine.**

Wipe the treadmill down after each use to keep the treadmill clean and dry. It may be necessary to use a mild dish soap at times to remove all dirt and salt from the belt, painted parts and the display.

**NOTICE:** If necessary, only use a mild dish soap with a soft cloth to clean the Console. Do not clean with a petroleum based solvent, automotive cleaner, or any product that contains ammonia. Do not clean the Console in direct sunlight or at high temperatures. Do not apply too much moisture to the Console.

## Adjusting the Belt Tension

If the walking belt starts to slip during use, it is necessary to adjust the tension. Your treadmill has tension bolts at the rear of the treadmill.

1. Remove the Safety Key and place it in a secure location.

**!** When this machine is not in operation, remove the Safety Key and keep out of the reach of children.

2. Make sure that the power switch is turned Off, and the power cord is disconnected.
3. Remove the Plugs from the Rear Covers to expose the Alignment Bolts.
4. Use a 6 mm hex wrench to turn the right and left belt adjustment bolts clockwise a 1/2 turn, first one bolt and then the other bolt.
5. After you adjust each side the 1/2 turn, inspect the walking belt. From the belt's midpoint, a correctly tensioned belt should only have an inch of give. To check, pull the belt upward at its midpoint and measure the distance to the deck. If the distance is more than an inch, the belt is loose. Repeat this step if necessary.

If you turn one side more than the other, the belt will move away from that side of the treadmill and may need realignment.

**NOTICE:** Too much tension on the belt causes unnecessary friction and wears the belt, motor and electronics.

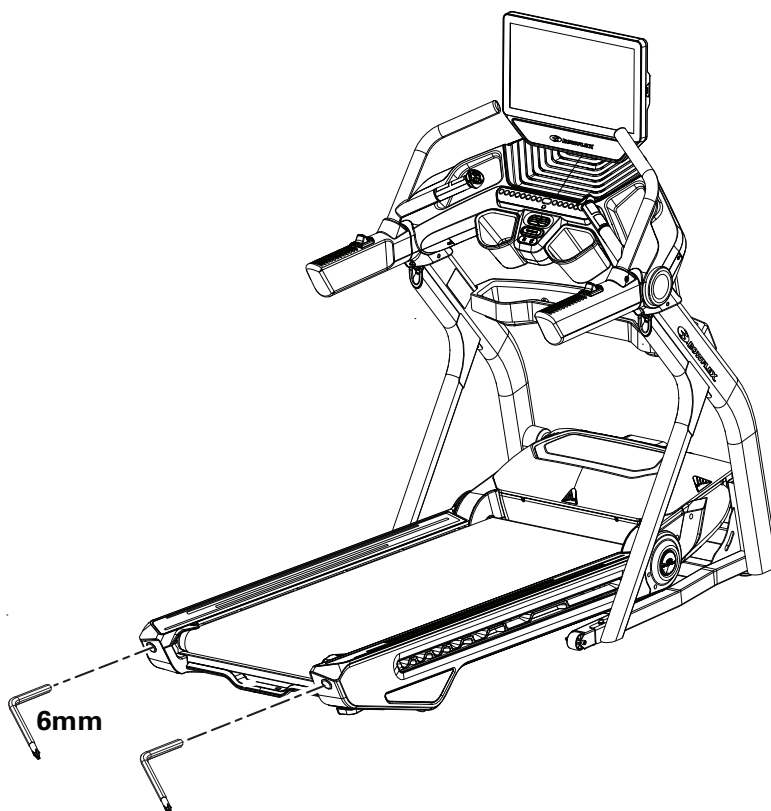

## Aligning the Walking Belt

The walking belt should be centered on your treadmill at all times.

Running style and a non-level surface can cause the belt to move off center. Minor adjustments to the 2 bolts at the rear of the treadmill are necessary when the belt is off center.

1. Remove the Plugs from the Rear Covers to expose the Alignment Bolts.
2. Push the START button to start the walking belt.

**!** Be sure not to touch the walking belt or step on the power cord. Keep bystanders and children away from the product you are servicing at all times.

3. Stand at the rear of the treadmill to see which direction the belt moves.
4. If the belt moves to the left, turn the left belt adjustment bolt 1/4 turn clockwise and the right belt adjustment bolt 1/4 turn counterclockwise. If the belt moves to the right, turn the left adjustment bolt 1/4 turn counterclockwise and the right adjustment bolt 1/4 turn clockwise.
5. Monitor the path of the belt for approximately 2 minutes. Continue to adjust the bolts until the walking belt is centered.
6. Push PAUSE/STOP twice to stop the walking belt and end the Quick Start workout.

## Lubricating the Walking Belt

Your treadmill is equipped with a low maintenance deck and belt system. The Walking Belt is pre-lubricated. Belt friction can affect the function and life of the machine. Lubricate the belt every 3 months or every 25 hours of use, whichever comes first. Even if the treadmill is not in use, silicone will dissipate and the belt will dry out. For the best results, lubricate the deck periodically with a silicone lubricant using the following instructions:

1. Turn off the power to the machine with the power switch.
2. Unplug the treadmill fully from the wall outlet, and remove the power cord from the machine.

### **DANGER**

**To reduce the risk of electrical shock, always unplug the power cord and wait 5 minutes before cleaning, maintaining or repairing this machine. Place the power cord in a secure location.**

3. Inspect the surface material below the Treadmill. If the surface material is difficult to clean or could be damaged by silicone lubricant, place absorbent material (such as cardboard or newspaper) below the length of the Walking Deck.
4. Carefully lift the belt and apply a few drops of the lubricant the entire width of the belt. A very thin layer of silicone lubricant on the entire deck below the belt is desired.

**NOTICE:** Always use a 100% pure silicone lubricant. Do not use a degreaser like WD-40® as this could seriously impact performance. We can recommend that you use the following:

- 100% pure silicone, available at most hardware and auto parts stores.
- Lube-N-Walk® Treadmill Lubrication Kit, available from your local specialty fitness dealer or Nautilus, Inc.

 **Silicone lubricant is not intended for human consumption. Keep out of reach of children. Store in a safe place.**

5. Manually rotate the belt 1/2 of the length of the belt and apply lubricant again.

 **If you used spray lubricant, wait 5 minutes before turning on power to the machine to allow the aerosol to dissipate.**

6. Connect the power cord back into the machine and then into the wall outlet.
7. Turn on the power to the machine with the power switch.
8. Stay to one side of your machine and start the belt at the slowest speed. Let the belt operate for approximately 15 seconds.

 **Be sure not to touch the walking belt or step on the power cord. Keep bystanders and children away from the product you are servicing at all times.**

9. Switch off your machine.
10. Take care to clean up any excess lubricant from the deck.

 **To decrease the possibility of slipping, be sure the deck area is free from grease or oil. Clean off any excess oil from the machine surfaces.**

# Maintenance Parts

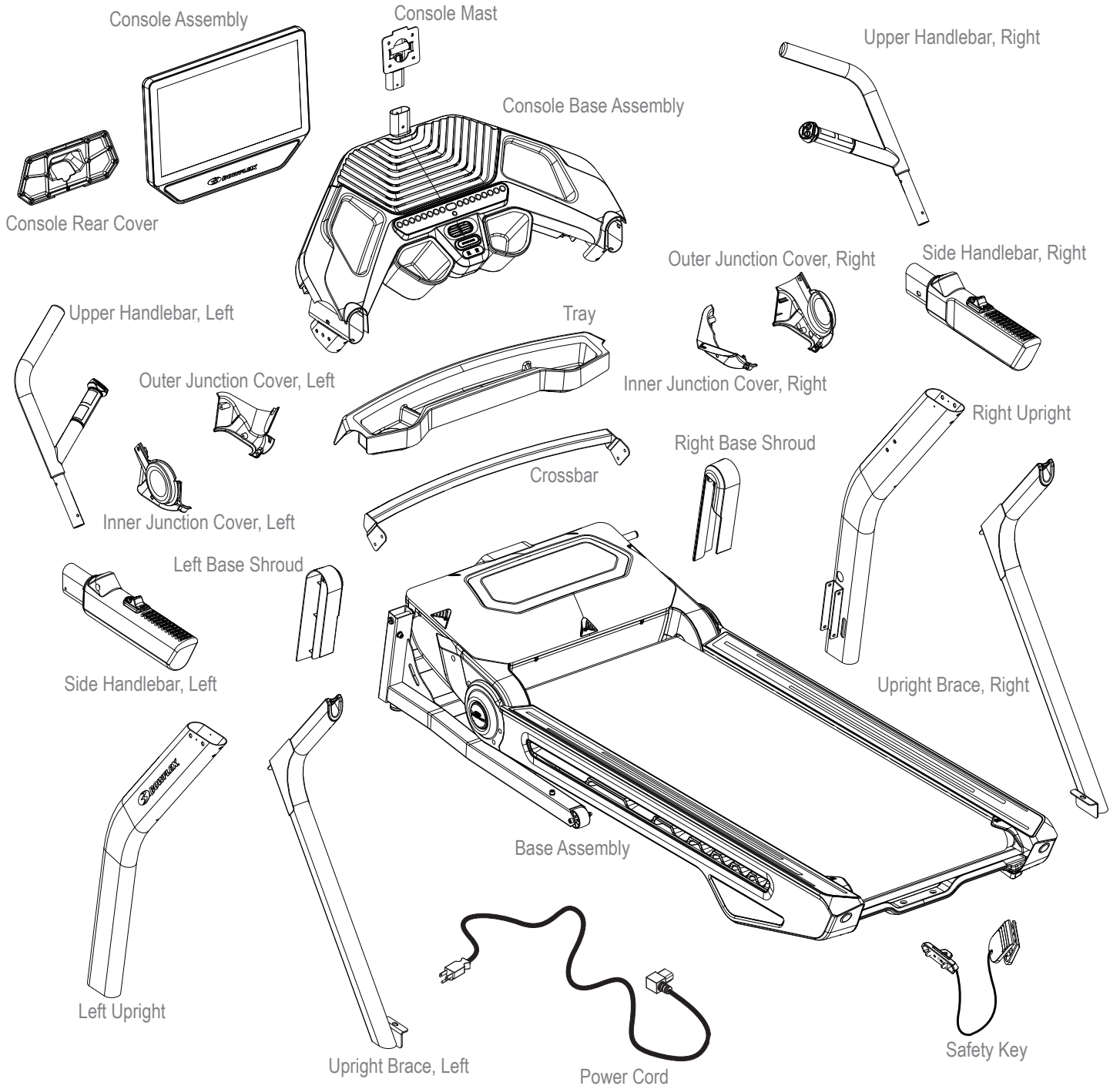

## Maintenance Parts (Base Assembly)

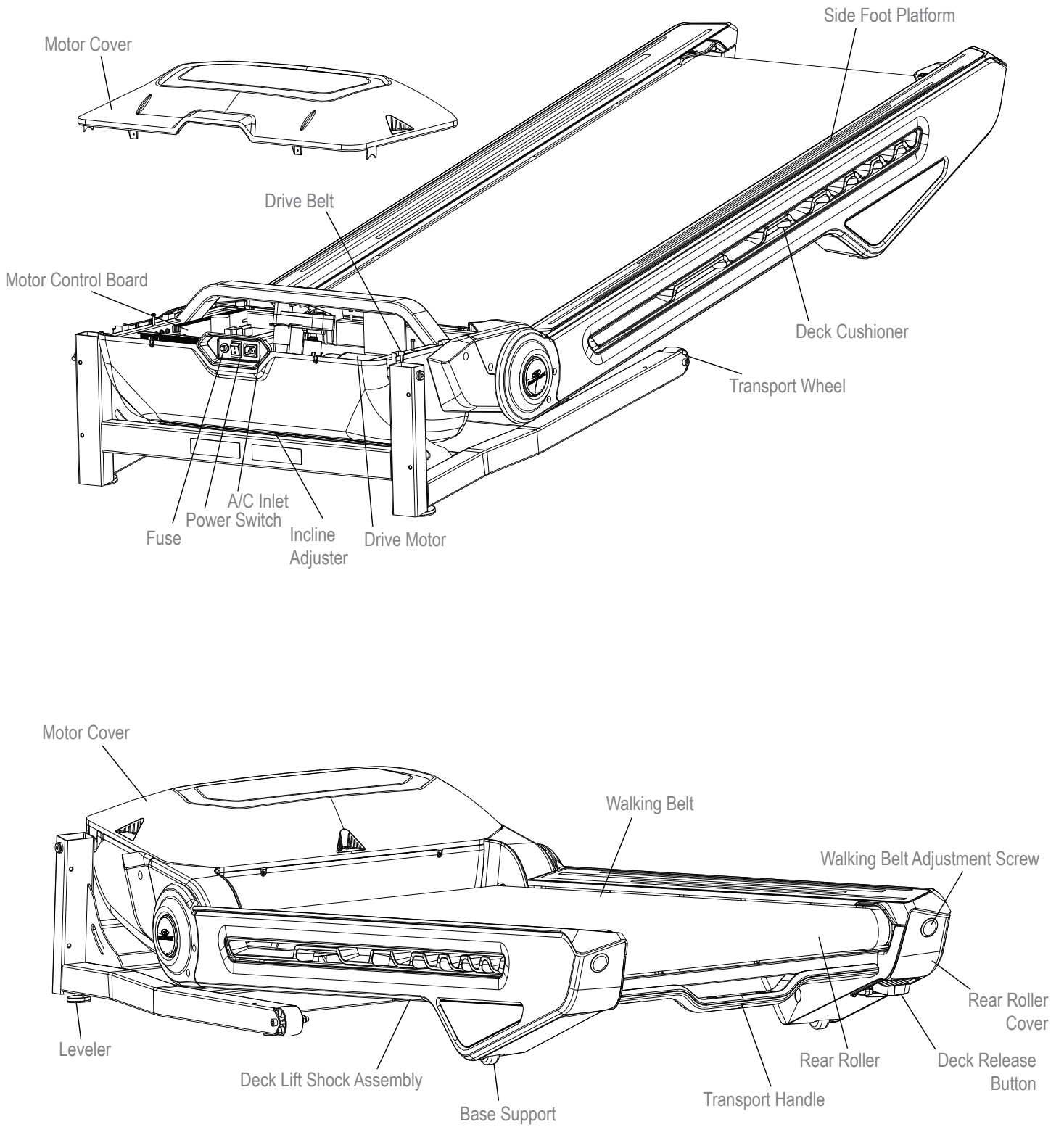



Condition/Problem	Things to Check	Solution
No display/unit will not turn on	Console in sleep mode	Touch display to wake up Console.
	Power Switch	Make sure that the Power Switch is flipped to on.
	Power Cord	Check for visual sign that Power Cord is damaged. Replace Power Cord if damaged.
	Check electrical (wall) outlet	Make sure unit is plugged into a functioning wall outlet.
	Check connection at front of unit	Connection should be secure and undamaged. Unplug connector and inspect inlet for any damage. Plug connector back into inlet.
	Check Status LED	If Status LED blinking quickly, then Console is experiencing an error. Disconnect power to machine for 30 seconds, and then reconnect it.
	Check data cable connections/orientation	Be sure cable is connected securely and oriented properly. Small latch on connector should line up and snap into place.
	Check data cable integrity	All wires in cable should be intact. If any are visibly crimped or cut, replace cable.
	Check console display for damage	Check for visual sign that console display is cracked or otherwise damaged. Replace Console if damaged.
		If the above steps do not resolve the problem, contact Customer Service (if inside US/Canada) or your local distributor (if outside US/Canada).
Speed or Incline does not adjust (machine turns on and operates)	Check data cable integrity from Console Button Assembly to Console	All wires in cable should be intact. If any are visibly crimped or cut, replace cable.
	Check data cable connections/orientation	Be sure cable is connected securely and oriented properly. Small latch on connector should line up and snap into place.
	Check Console display for damage	Check for visual sign that console display is cracked or otherwise damaged. Replace Console if damaged.
		If the above steps do not resolve the problem, contact Customer Service (if inside US/Canada) or your local distributor (if outside US/Canada).
Unit operates but Bluetooth® Heart Rate (HR) not displayed	Bluetooth® HR device	Fully charge HR device and activate. Be sure any protective cover has been removed from HR sensors. Make sure sensors are directly against skin and contact area is wet.
	Heart Rate Strap Batteries	If HR device has replaceable batteries, install new batteries (the provided heart rate armband does not have replacement batteries).
	Interference	Try moving unit away from sources of interference (TV, Microwave, etc).
	On/Off LED button on HR device	During a workout, only push the On/Off LED button once to activate the armband.
	Replace HR device	If interference is eliminated and HR does not function, replace HR device.
		If the above steps do not resolve the problem, contact Customer Service (if inside US/Canada) or your local distributor (if outside US/Canada).
Speed display is not accurate	Display set to wrong unit of measure. (English/Metric)	Change display to show correct units.
Fan will not turn on or will not turn off	Reset machine	Unplug unit from electrical outlet for 5 minutes. Reconnect to outlet.
Fan will not turn on, but Console operates	Check for blockage of fan	Unplug unit from electrical outlet for 5 minutes. Remove material from fan. If necessary, detach the Console to help with removal. Replace the Console if unable to remove blockage.
Unit rocks/does not sit level	Check leveler adjustment	Adjust levelers until machine is level.
	Check surface under unit	Adjustment may not be able to compensate for extremely uneven surfaces. Move machine to level area.
Thumping sound when belt operates	Walking belt	Walking belt needs to be used for wear in period. Sound will go away after the wear in period.

Walking belt not aligned	Machine leveling	Make sure the machine is level. Refer to the procedure for leveling the machine in this manual.
	Walking belt tension and alignment	Make sure the walking belt is centered and tension is correct. Refer to the procedures for adjusting tension and aligning the belt in this manual.
Motor sounds strained	Walking deck	Apply a thin layer of silicone lubricant on the entire deck below the belt. Refer to the belt lubrication procedure in this manual.
Hesitation or walking belt slips when in use	Belt tension	Adjust the belt tension at the rear of the machine. Refer to the procedure for adjusting belt tension in this manual.
Belt stops moving while in use	Safety key	Plug Safety Key into Console. (See Emergency Stop Procedure in the Important Safety Instructions section.)
	Motor overload	Unit may be overloaded and draw too much current, which causes power to turn off to protect motor. Refer to maintenance schedule for belt lubrication. Make sure the walking belt tension is correct, and start unit again.
		If the above steps do not resolve the problem, contact Customer Service (if inside US/Canada) or your local distributor (if outside US/Canada) for further assistance.
Console continuously displays a video of machine features	Console is in demonstration mode	Tap on the upper-right corner of the console display ten times. Tap on "Demo mode app", and then tap on the "De-activate Demo mode" option.

## Introduction and Overview

Welcome to the Bowflex™ Body Weight Loss Guide. This guide is designed to be used with your Bowflex™ equipment and will help you:

- Lose weight and get lean
- Improve your health and wellness
- Increase your energy and vitality

**⚠ Consult a physician before you start an exercise program or a new health and diet plan. Stop exercising if you feel pain or tightness in your chest, become short of breath, or feel faint. Contact your doctor before you use the machine again. Use the values calculated or measured by the machine's computer for reference purposes only. The heart rate displayed on the console is an approximation and should be used for reference only.**

By focusing on the main three elements of the Bowflex™ Body Weight Loss Guide- quality, balance, and consistency- you'll be able to reach and maintain your weight loss and fitness goals for the next six weeks and beyond.

- **Quality** – The emphasis of this plan is on eating more whole foods and getting the most nutrients from your calories as possible. Making the majority of your diet from foods that have a single ingredient (for example fruits, vegetables, fish, lean protein, eggs, beans, nuts, and whole grains) provides the vitamins, minerals, fiber, protein, and healthy fats your body needs.
- **Balance** – Each of the meals and snacks in this guide have a source of fiber or smart carbohydrate, protein, and healthy fat to keep your energy levels consistent throughout the day to fuel your workouts. By having this balance you'll feel fuller longer, which is critical to weight loss success.
- **Consistency** – Getting about the same number of calories each day is important for your metabolism and your mindset. If you overdo it one day, don't try to make up for it the next day by not eating or cutting your calories drastically. Get right back on track by following this guide!

## Results & Expectations

Results will vary depending on your age, starting weight, and exercise level but on average you may lose 1-3 lbs per week and experience increased energy levels.

## 5 Tips for Long-Term Success

1. **Keep a food log** including hunger levels and water intake. Free online food logs and mobile apps are available at [www.myfitnesspal.com](http://www.myfitnesspal.com) and [www.loseit.com](http://www.loseit.com)
2. **Weight and/or take measurements weekly** – no more and no less. Weighing weekly rather than daily or every other day is best. You'll track your progress and keep yourself in check without getting discouraged if the scale doesn't move for a few days. And remember, weight is just a number and it's influenced by muscle gain as well as fat loss. Feeling how your clothes fit can often be a better indicator of progress as your body adapts to exercise and nutrition changes.
3. **Measure portions** – To avoid portion creep, use measuring cups and spoons for grains (rice, pasta, cereal), beans, nuts, oils, and dairy. Use the Portion Sizes Guide for other foods.
4. **Plan ahead** – Make a meal plan for the week or log your food a day in advance. Planning sets you up for success, especially for social events and eating out.
5. **Practice your desired long-term habits** – It's easy to justify poor eating choices when you're only focused on the short term. Focus on the long term satisfaction of a slimmer, healthier you rather than the temporary gratification you'll get from splurging.

## How to Use this Guide

- **Eat breakfast within 90 minutes of waking up and balance your meals and snacks throughout the day**
  - Don't go longer than 5-6 hours without eating
  - If you're not used to eating breakfast, start out small with a piece of fruit and have something else 1-2 hours later. Your body adapts to not eating breakfast, but as soon as you start eating early in the day and cutting back on dinner portions you'll notice your hunger will increase. This is a good sign your metabolism is working!
- **Mix and match meal options**
  - Select 1 option from the appropriate meal plan (male or female) for breakfast, lunch, and dinner, paying close attention to portion sizes
  - Select 1-2 snack options per day
  - You have the option to substitute one snack for one treat under 150 calories
  - Use the meal plan, sample options, and grocery list to create your own meals for more variety

- You can swap out any type of protein, vegetables or smart carbs for the suggested meal options. For example:
  - Turkey for tuna
  - Any fish or seafood for chicken
  - Cooked vegetables instead of salad
- **Eat your calories**
  - Cut out high calorie beverages like soda, juices, coffee drinks, and alcohol
  - Stick with water, unsweetened tea, and coffee. Aim for a minimum of 64oz (1.9 liters) of water per day to stay well hydrated
- **If you're still hungry after or in between meals:**
  - Have a glass of water and wait 15-20 minutes. Many times we mistake thirst (or even boredom!) for hunger. Wait out the initial urge to eat and sometimes it will pass.
  - If you're still hungry after waiting 15-20 minutes have a snack or mini-meal with fruit, vegetables, and protein.

#### **If your goal is muscle gain or strength:**

- Use the same meal plan but increase portion sizes in the same ratios to increase the total number of calories you eat every day. For example, increase portion sizes of protein and smart carbs at meals by 50%. Adding a snack is another option to meet your body's increased calorie needs in order to gain muscle and strength.
- Focus on post-workout nutrition by having one of your snacks within 30 minutes after you complete your workout. Make sure to have a combination of carbohydrates such as fruit with protein (yogurt, milk, or protein powder) to promote muscle growth and recovery. Chocolate milk is also a great option.

## **Meal Plan Overview**

The female meal plan provides about 1400 calories, and the male plan provides about 1600 calories, of high quality nutrition to not only help you lose weight and feel great but get the most out of your calories. The vitamins, minerals, and antioxidants from eating mostly whole foods help support optimal health. These calorie levels will result in healthy weight loss for the majority of people. Keep in mind that everyone's metabolism is very different depending on age, height, weight, activity level, and genetics. Pay close attention to your weight, hunger levels, and energy and adjust your calories if needed.

#### **Follow these guidelines if you're over 55:**

- If you're over 55, you need fewer calories because your metabolism slows as you age. Stick with three meals with one optional snack per day.

#### **Follow these guidelines if you're under 25:**

- If you're under 25 you may need more calories. Add another snack if you feel low on energy or are extremely hungry.

## **Breakfast**

Breakfast includes a smart carb, fruit, and a source of protein, which will also have fat. With a balance of carbohydrates and fiber from the smart carb and fruit combined with protein and fat, you'll energize your day and help control hunger levels throughout the day.

## **Snacks**

Each snack is a balance of carbohydrates and protein to keep your blood sugar more consistent, which means you won't experience hunger and energy level spikes and drops.

This happens when you have a high carb-only snack like chips, candy, soda, crackers, or pretzels.

## **Lunch and Dinner**

Lunch combines filling fiber from vegetables and smart carbs with a lean, or low-fat, protein. The healthy fat can come either from the protein added during cooking (nuts on a salad) or as a dressing or sauce (such as oil and vinegar salad dressing).

Here's an overview of what an ideal day looks like:  
(See Portion Size Guide for proper serving sizes)

### Breakfast

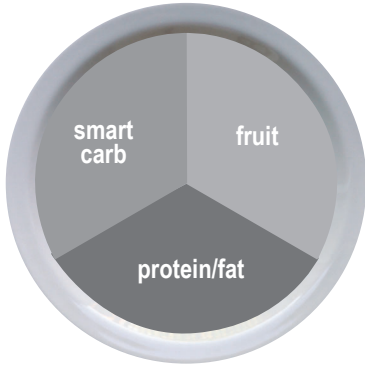

### Snack #1

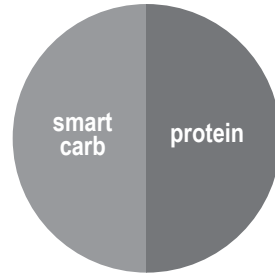

### Lunch

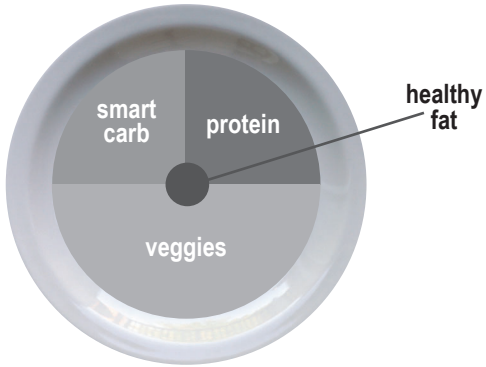

### Snack #2

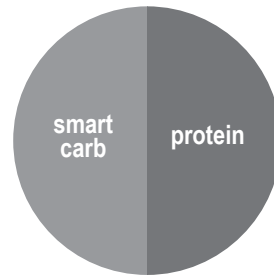

### Dinner

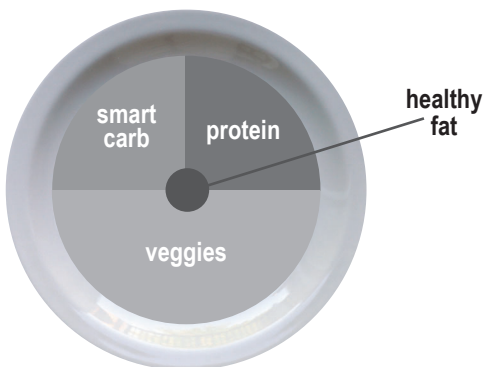

<b>Breakfast Options</b>	<b>Fruit</b>	<b>Smart Carb</b>	<b>Protein/Fat</b>
<b>Fruit and Nut Oatmeal</b> Cook plain oats in water. Top with fruit, nuts, milk, cinnamon, and honey.	Berries or banana	Plain oats (Regular or quick-cook)	Nuts and milk
<b>Egg Muffin</b> Cook egg/s. Toast bread and top with 1 slice of cheese, 1 slice of ham, and tomato.	Tomato	English muffin or sandwich thin	Egg, ham, and cheese
<b>Yogurt Power Parfait</b> Top yogurt with fruit. Sprinkle with 1 serving of nuts, 2-3 tbsp wheat germ, or ground flaxseed, 1 tbsp oats, and cinnamon.	Chopped fruit of your choice	Oats, wheat germ, and ground flaxseed	Plain non-fat Greek yogurt and nuts
<b>On the Go PB &amp; Apple Sandwich</b> Toast bread. Spread on peanut butter, thin slices of ½ an apple, and 1 teaspoon of honey.	Sliced apple	Sandwich thin, bread, or bagel thin	Peanut butter

<b>Lunch &amp; Dinner Options</b>	<b>Lean Protein</b>	<b>Smart Carb</b>	<b>Veggies</b>
<b>Pork Loin, Sweet Potato &amp; Green Beans</b>	Grilled or baked pork loin	Baked Sweet Potato	Green Beans
<b>Chicken Stir Fry</b> Flavor with 2 tablespoon teriyaki sauce	Chicken breast or boneless skinless thigh	Brown or wild rice	Mixed stir fry vegetables (fresh or frozen)
<b>Steak Tacos with Side Salad</b> (3 for males, 2 for females) Top with salsa, cilantro, and sprinkle of shredded cheese	Flank or sirloin steak	Corn tortillas	Salad
<b>Whole Wheat Pasta with Shrimp or Cannellini Beans &amp; Marinara Sauce</b>	Shrimp (frozen or fresh) or cannellini beans	Whole wheat pasta	Steamed broccoli
<b>Bunless Burgers with Oven Fries, Corn, &amp; Salad</b> Grill burgers. Bake sliced potatoes on sprayed cookie sheet for 25-30 minutes @ 425°F.	93% lean ground beef or turkey	Oven baked fries	Corn on the cob + side salad
<b>Tuna &amp; Avocado Wrap with Vegetable Soup</b> Use 3oz of tuna (1 can). Top with lettuce, tomato, avocado, and mustard.	Tuna	High-fiber wrap	Vegetable soup (homemade or low-sodium canned)

Snack Options	
Smart Carb	Protein
1 medium apple	10-15 almonds
Baby carrots	2 tbsp hummus
1 serving of crackers*	1 string cheese
Energy or protein bar with <200 calories*	

\*See [www.Bowflex.com/Resources](http://www.Bowflex.com/Resources) for brand recommendations

## Optional Treats

You have the choice of replacing Snack #2 with a 100-150 calorie treat. You can have an optional treat every day but for optimal health it is recommended to limit small splurges to 3-4 times per week. Use the approach that works best for you. Here are a few examples:

- ½ cup lowfat ice cream
- 1 small bag of baked potato chips
- 4oz of wine or 12oz light beer
- 3 cups of air-popped or light popcorn

## Sample 3 Day Plan

Based on each of the meal options listed above, a typical 3 day plan could look like this:

	Day 1	Day 2	Day 3
<b>Breakfast</b>	Egg muffin	Power yogurt parfait	Fruit + nut oatmeal
<b>Snack 1</b>	Apple with almonds	Nut Thins® + string cheese	Baby carrots and hummus
<b>Lunch</b>	Tuna & avocado wrap with soup	Leftovers from dinner- day 1	Leftovers from dinner- day 2
<b>Optional Snack 2 or Treat</b>	½ cup ice cream bar	Energy bar	100 calorie bag of light popcorn
<b>Dinner</b>	Shrimp pasta	Chicken stir fry	Bunless burgers



## Portion Size Guide

Each of the items listed are for one serving

MALE	FEMALE
<b>PROTEIN</b>	
2 eggs 5oz chicken, fish, lean meat, or tofu 2/3 cup beans or lentils* 1 cup greek yogurt* 1.5oz cheese*	1 egg 3oz chicken, fish, or lean meat 1/2 cup beans or lentils* 1/2 cup greek yogurt* 1.5oz cheese*
<b>HEALTHY FAT</b>	
2 Tblspn peanut or nut butter* 2 tspn olive, flax, or walnut oil 1/4 cup of nuts 1/3 medium avocado	1 tblspn peanut or nut butter* 1 tspn olive, flax or walnut oil 1/8 cup or 2 tablespoons of nuts (approx. 15 almonds) 1/4 medium avocado
<b>SMART CARB</b>	
1 cup cooked grains (1/2 cup raw): oats, brown rice, quinoa, pasta 1 medium sweet or regular potato 2 corn tortillas 1 slice of bread (or 2 light slices equaling 120 calories or less) 1 english muffin, sandwich thin, or high-fiber wrap	1/2 cup cooked (1/4 cup raw) grains 1/2 medium sweet potato or regular potato 2 corn tortillas 1 slice of bread (or 2 light slices equaling 120 calories or less) 1 english muffin, sandwich thin, or high-fiber wrap
<b>FRUIT</b>	
1 medium apple, orange, or pear 1 small banana (length of your hand) 1 cup berries or chopped fruit 1/4 cup dried fruit (fresh or frozen is optimal)	
Vegetables* You can have unlimited vegetables except for peas and corn; stick with 1/2 cup serving	
2 cups spinach or lettuce = 2 cupped hands 1 cup raw vegetables 1/2 cup cooked vegetables 6oz low sodium vegetable juice	
<b>OPTIONAL TREATS</b>	
1/2 cup lowfat ice cream 1 small bag of baked potato chips 1oz dark chocolate 4oz of wine or 12oz light beer 3 cups air-popped or light popcorn	

\* some foods are a combination of protein and carbs or protein and fat



1 cup = baseball



1/2 cup = lightbulb



1 oz or 2 tbsp = golf ball

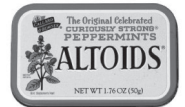

1/4 cup nuts = Altoids tin



3 oz chicken or meat = deck of cards



1 medium potato = computer mouse



1 medium piece of fruit = tennis ball



1 - 1/2 oz cheese = 3 dice

## Grocery List

<b>BREAD &amp; GRAINS</b>			
100% whole wheat bread Sprouted grain breads Light or whole wheat english muffins Sandwich or bagel thins Corn or low-carb whole wheat tortillas High-fiber wraps Plain oats: 1 minute or old fashioned Whole grains: brown rice, bulgar, barley, quinoa, couscous	Tips: Look for 100% whole wheat as the first ingredient. Look for 4g of fiber per slice or 5g per 2 slices of light or diet bread. Aim for bread with less than 100 calories per slice.		
<b>DAIRY &amp; DAIRY ALTERNATIVES</b>	<b>CRACKERS, SNACKS &amp; ENERGY BARS</b>		
Plain non-fat greek yogurt Kefir (yogurt like drink) Organic low-fat milk Enriched almond or soy milk Cheese: feta, parmesan, mozzarella, light havarti, provolone, swiss, string cheese, or single serving packages	<table border="1"> <tr> <td>           Any unsalted nuts or seeds            Air-popped or light popcorn            Edamame in the pod         </td> <td>           Energy bars            Crackers            Hummus         </td> </tr> </table>	Any unsalted nuts or seeds Air-popped or light popcorn Edamame in the pod	Energy bars Crackers Hummus
Any unsalted nuts or seeds Air-popped or light popcorn Edamame in the pod	Energy bars Crackers Hummus		
<b>MEAT, FISH, POULTRY &amp; PROTEIN</b> Wild game Salmon, halibut, tuna, tilapia, shrimp, catfish, scallops, or crab Pork loin, pork chops, or pork roast Chicken or turkey breast or thighs (no skin) Eggs and 100% egg whites Lean beef: sirloin, chuck, round, tenderloin, 93% lean (organic and grass fed is best) Canned salmon or tuna (in water) Nitrate-free, reduced sodium ham, turkey, chicken, or roast beef lunch-meat Any type of bean, dry or canned low-sodium varieties Tofu and tempeh Tips: Look for "Choice" or "Select" cuts of meat rather than "Prime". Prime cuts are fattier. Limit intake of highly processed meat and imitation meat products like sausage, bacon, pepperoni, and hot dogs to once a week or less.	Tips: Limit crackers, pretzels, and chips to 2-3 servings per week. Always pair with protein such as hummus, cheese, or nuts. Look for energy bars with less than 200 calories and 20g of sugar and at least 3g of protein and 3g of fiber. Look for crackers with less than 130 calories and 4g or less of fat per serving.		
<b>FROZEN FOODS</b> All vegetables without sauce All fruit Grains and grain medleys	<b>FATS &amp; OILS</b> Avocado Olive, grapeseed, walnut, sesame, or flaxseed oil Butter/spreads: look for products free of trans fats and partially hydrogenated oils on the ingredient list. Tips: Light olive oil refers to the flavor, not the calorie content. Always measure oil and butter. Even if a fat is considered healthy, it's still very high in calories and portions need to be controlled.		
	<b>DRESSINGS, CONDIMENTS &amp; SAUCES</b> Vinegars: rice, wine, balsamic All fresh or dried herbs and spices Mustard Salsa and chili sauce Marinara sauce with no high-fructose corn syrup Lemon and lime juice Bottled minced garlic and ginger Low-sodium soy sauce Tips: Look for products free of MSG, added colors, and high fructose corn syrup. Look for sauces under 50 calories per serving. Avoid cream based sauces and dressings like ranch, bleu cheese, and alfredo.		

All fruits and vegetables, fresh and frozen, are great choices. Since every meal has one or both, your shopping cart should reflect this.

## Keep It Going

### Tips for continued weight loss and maintaining changes

- **Keep weighing yourself weekly**, even after you've reached your goal weight
- **Continue keeping a food log**. If you have your meal plan well-established, log your food every other week to keep yourself on track. Don't feel like you have to do it every day.
- **Prepare for plateaus**. The scale might not budge for a few weeks or even months after some initial weight loss. This is normal and to be expected. It's the body's natural process for adjusting to your new lower weight. Stay focused on your long-term goal, celebrate your successes and changes, and mix up your workouts to help overcome the plateau.
- **Calorie adjustments for maintaining weight loss**. Once you've reached your goal weight, you can increase your calories 100-200 per day as long as your activity level stays the same
- **Treat yourself**. Have a non-food reward for each goal you hit such as a massage, a new outfit, or an outing with friends and family
- **Use the resources below** to find new recipes, get expert advice, and support to stay motivated

## Resources

### Downloadable Resources from Bowflex™ Website ([www.Bowflex.com/Resources](http://www.Bowflex.com/Resources))

- Grocery Shopping List for Fridge (Blank Form)
- 7 Day Meal Planning Form
- Additional Dinner Options
- Pre and Post Workout Fueling Guide

### Questions & Support

- Ask questions, post suggestions, and connect with our online Bowflex™ Dietitian on the Bowflex Facebook page

### Recipes

- [www.wholeliving.com](http://www.wholeliving.com)
- [www.eatingwell.com](http://www.eatingwell.com)
- [www.whfoods.org](http://www.whfoods.org)
- [www.livebetteramerica.org](http://www.livebetteramerica.org)

### Online food logs

- [www.myfitnesspal.com](http://www.myfitnesspal.com)
- [www.loseit.com](http://www.loseit.com)





#### Who Is Covered

This warranty is valid only to the original purchaser and is not transferable or applicable to any other person(s).

#### What Is Covered

Nautilus, Inc. warrants that this product is free from defects in materials and workmanship, when used for the purpose intended, under normal conditions, and provided it receives proper care and maintenance as described in the Product's Assembly and Owner's manual. This warranty is good only for authentic, original, legitimate machines manufactured by Nautilus, Inc. and sold through an authorized agent and used in the United States or Canada.

#### Terms

Warranty terms for products purchased in US/Canada are as stated below.

- Frame 15 years
- Drive Motor 15 years
- Mechanical parts 5 years
- Electronics 1 year
- Labor 2 years

(Labor support does not include the installation of replacement parts involved in the initial product assembly and preventative maintenance services. All repairs covered under the labor portion of the warranty must be preauthorized by Nautilus.)

For warranty & service of products purchased outside US/Canada, please contact your local distributor. To find your local international distributor, go to: [www.nautilusinternational.com](http://www.nautilusinternational.com)

#### How Nautilus Will Support the Warranty

Throughout the terms of the warranty coverage, Nautilus, Inc. will repair any machine that proves to be defective in materials or workmanship. Nautilus reserves the right to replace the product in the event a repair is not possible. When Nautilus determines replacement is the correct remedy, Nautilus may apply a limited credit reimbursement toward another Nautilus, Inc. brand Product, at our discretion. This reimbursement may be prorated based on length of ownership. Nautilus, Inc. provides repair service within major metropolitan areas. Nautilus, Inc. reserves the right to charge the consumer for travel outside these areas. Nautilus, Inc. is not responsible for dealer labor or maintenance charges beyond the applicable warranty period(s) stated herein. Nautilus, Inc. reserves the right to substitute material, parts or products of equal or better quality if identical materials or products are not available at the time of service under this warranty. Any replacement of the product under the terms of the Warranty in no way extends the original Warranty period. Any limited credit reimbursement may be prorated based on length of ownership. THESE REMEDIES ARE THE EXCLUSIVE AND SOLE REMEDIES FOR ANY BREACH OF WARRANTY.

#### What You Must Do

- Retain appropriate and acceptable Proof of Purchase.
- Operate, maintain, and inspect the Product as specified in the Product Documentation (Assembly, Owner's Manuals, etc.).
- Product must be used exclusively for the purpose intended.
- Notify Nautilus within 30 days after detecting an issue with the Product.
- Install replacement parts or components in accordance with any Nautilus instructions.
- Perform diagnostic procedures with a trained Nautilus, Inc representative if requested.

#### What Is Not Covered

- Damage due to abuse, tampering or modification of the Product, failure to properly follow assembly instructions, maintenance instructions, or safety warnings as stated in the Product Documentation (Assembly, Owner's Manuals, etc), damage due to improper storage or the effect of environmental conditions such as moisture or weather, misuse, mishandling, accident, natural disasters, power surges.
- A machine placed or used in a commercial setting. This includes commercial gyms, clubs, fitness centers and any public or private entity that has a machine for use by its members, customers, employees or affiliates where dues, subscriptions or paid memberships are collected, or where the product is used more than 3 hours per day.
- Damage caused by exceeding maximum user weights as defined in the Product's Owner's manual or warning label.
- Damage due to normal usage and wear and tear.
- This warranty does not extend to any territories or countries outside the United States and Canada.

#### How to Obtain Service

For Products purchased directly from Nautilus, Inc. contact the Nautilus office listed on the Contacts page of the products Owner's manual. You may be required to return the defective component to a specified address for repair or inspection, at your expense. Standard ground shipping of any warranty replacement parts will be paid by Nautilus, Inc. For products purchased from a retailer, you may be asked to contact your retailer for warranty support.

#### Exclusions

The preceding warranties are the sole and exclusive express warranties made by Nautilus, Inc. They supersede any prior, contrary or additional representations, whether oral or written. No agent, representative, dealer, person or employee has the authority to alter or increase the obligations or limitations of this warranty. Any implied warranties, including the WARRANTY OF MERCHANTABILITY and any WARRANTY OF FITNESS FOR A PARTICULAR PURPOSE, are limited in duration to the term of the applicable express warranty provided above, whichever is longer. Some states do not allow limitations on how long an implied warranty lasts, so the above limitation may not apply to you.

#### Limitation of Remedies

EXCEPT AS OTHERWISE REQUIRED BY APPLICABLE LAW, THE PURCHASER'S EXCLUSIVE REMEDY IS LIMITED TO REPAIR OR REPLACEMENT OF ANY COMPONENT DEEMED BY NAUTILUS, INC. TO BE DEFECTIVE UNDER THE TERMS AND CONDITIONS STATED HEREIN. IN NO EVENT WILL NAUTILUS, INC. BE LIABLE FOR ANY SPECIAL, CONSEQUENTIAL, INCIDENTAL, INDIRECT OR ECONOMIC DAMAGES, REGARDLESS OF THE THEORY OF LIABILITY (INCLUDING, WITHOUT LIMITATION, PRODUCT LIABILITY, NEGLIGENCE OR OTHER TORT) OR FOR ANY LOST REVENUE, PROFIT, DATA, PRIVACY OR FOR ANY PUNITIVE DAMAGES ARISING OUT OF OR RELATED TO THE USE OF THE FITNESS MACHINE EVEN IF NAUTILUS, INC. HAS BEEN ADVISED OF THE POSSIBILITY OF SUCH DAMAGES. THIS EXCLUSION AND LIMITATION SHALL APPLY EVEN IF ANY REMEDY FAILS OF ITS ESSENTIAL PURPOSE. SOME STATES DO NOT ALLOW THE EXCLUSION OR LIMITATION OF CONSEQUENTIAL OR INCIDENTAL TYPE DAMAGES SO THE ABOVE LIMITATION MAY NOT APPLY TO YOU.

#### State Laws

This warranty gives you specific legal rights. You may also have other rights, which vary from state to state.

#### Expirations

If the warranty has expired, Nautilus, Inc. may assist with replacements or repairs to parts and labor, but there will be a charge for these services. Contact a Nautilus office for information on post-warranty parts and services. Nautilus does not guarantee availability of spare parts after expiration of warranty period.

#### International Purchases

If you purchased your machine outside of the United States consult your local distributor or dealer for warranty coverage.

